



Diamond Micron Powder



多晶 · 單晶鑽石膏
Diamond Compound

- DIAMOND MICRON POWDER
- DIAMOND COMPOUND
- (NANO) DIAMOND SLURRY
- DIAMOND NYLON BRUSH
- DIAMOND MOUNTED POINTS

拋光耗材對應參考	Reference Table ...01
拋光皮類	...02
鑽石粒度規格表	Diamond Grit Size Chart ...04
多晶 / 單晶鑽石粉 / 膏 / 液	Diamond Micron Powder/Compound/Slurry ...05
奈米鑽石粉 / 膏 / 拋光液	Ultradispersed/Nanodiamonds Powder/Paste/Slurry ...06
氧化鋁 (鈹) 拋光粉 / 膏 / 液	Aluminum Oxide Powder/Paste/Slurry ...07
羊毛輪	Felt Bobs ...08
貝斯迪亞纖維油石	BESDIA Ceramic Fiber Stones ...09
迷你纖維油石	Mini Ceramic Fiber Stones ...09
鑽石油石	Diamond Stones ...10
鑽石纖維油石	Ceramic Diamond Stones ...10
油石夾柄	Tool Holders ...11
油石	Oil Polishing Stones ...11
彈性帶柄砂輪	Elastic Mounted Points ...11
木條、木棒及棕刷	Lapping Wood Stick & Wood Bobs & Brush ...12
鑽石·氮化硼內孔磨棒	Diamond & CBN Internal Points ...13
鑽石磨棒	Diamond Mounted Points ...14 - 17
鑽石修刀	Diamond Dressing Tools ...18 - 19
聚晶鑽石、氮化硼車刀	PCD & PCBN Turning Tools ...20
鑽石銼刀	Diamond Files ...21 - 25
粉紅帶柄砂輪	Mounted Points ...26
電鑄鑽石鑽管	Electroplated Diamond Core Drills ...26
鑽石切片	Plated Diamond Disc ...27
電鑄鑽石鋸片	Electroplated Diamond Cutters ...27
鑽石與氮化硼砂輪	Diamond & CBN Grinding Wheels ...28
砂輪形狀及尺寸標示	Shape & Dimensions of wheels ...29
電鑄鑽石砂輪	Electroplated Diamond wheels ...30
樹脂鑽石砂輪	Resinoid Diamond & CBN Wheels ...31
鑽石毛刷 (輪)	Diamond Nylon Brush/Wheel ...32 - 33
旋轉式電動工具 - 電源控制器	Rotary Micromotor Controller ...34 - 38
電動旋轉手機	Rotary Handpiece ...39
超音波振動研磨機	Ultrasonic Lapping Machine ...40 - 41
超音波振動研磨機 - 手機	Ultrasonic Lapping Machine-Handpiece ...42
U-Lap 氣動刻磨機	Air Grinders ...43
U-Lap 氣動 (左右) 銼磨機	Pneumatic (Reciprocating/Swing) Lappers ...44
超音波振動研磨機	Ultrasonic Lapping Machine ...45
旋轉毛刷機	Variable Speed Brushing Machine ...46
鏡面拋光設備	Polishing Equipment ...47 - 48
稀有原物料	Rare Earth Materials ...49

拋光耗材對應參考

Reference Table

BRIGHT-POLISHED

產品名稱 Product name		半導體材料 Semiconductor				電子材料 Electronic material			金屬材料 Metallic	
種類 Type	分類 Grade	Bare	GaAs	GaP	InP	LiNbO ₃	Sapphire	Crystal	Hard metal	Soft metal
鑽石粉	Dia-P						●		●	
碳化矽	GC,C	●					●	●	●	
氧化鋁	WA,A	●	●	●	●	●		●		●
石榴粉	GW		●	●	●					●
鑽石拋光液	DP senes						●		●	
	CP senes									
	SP senes									
	OP senes									
氧化鈣粉	Metal senes								●	●
	Crystal senes	●				●	●	●		
氧化鋁拋光液	Platic senes									
	Metal senes		●	●	●				●	●
拋光墊	Cerium Pad								●	●
	Mout Pad									
	W series	●					●	●		●
	B series	●	●	●	●	●			●	

產品名稱 Product name		陶瓷材料 Ceramics			塑膠材料 Plastic		玻璃材料 Glass		
種類 Type	分類 Grade	Barium Titanate	Alumina ceramics	Sic ceramics	Plastic materials	Plastic lens	Optical lens	Optical glass	LCD glass
鑽石粉	Dia-P	●	●	●					
碳化矽	GC,C	●	●	●			●	●	●
氧化鋁	WA,A				●	●	●	●	●
石榴粉	GW						●	●	●
鑽石拋光液	DP senes	●	●	●					
	CP senes								●
	SP senes							●	
	OP senes						●		
氧化鈣粉	Metal senes								
	Crystal senes	●	●	●				●	●
氧化鋁拋光液	Platic senes								
	Metal senes								
拋光墊	Cerium Pad	●	●	●			●	●	●
	Mout Pad							●	●
	W series							●	
	B series	●	●	●	●	●	●	●	●

聚胺酯類拋光皮

聚胺酯拋光皮，是由聚胺酯所發泡製成，其內含物能填充研磨材料，包括：氧化銻、氧化鋯及純聚胺皮，本系列產品可搭配不同的拋光液，廣泛運用於光學晶體、光學平板玻璃、LCD基板減薄、金屬、合金、陶瓷材料，具有良好的拋光與平坦化特性。

產品型號	填充磨料	平均硬度	適用材質				
			硬質玻璃	軟質玻璃	晶體	陶瓷	合金
FC-15	氧化銻	62~66	●	●	●		
FC-01	氧化銻	75~80	●	●			●
FC-03	氧化鋯	70~75			●	●	
FC-05	氧化鋯	88~90			●	●	

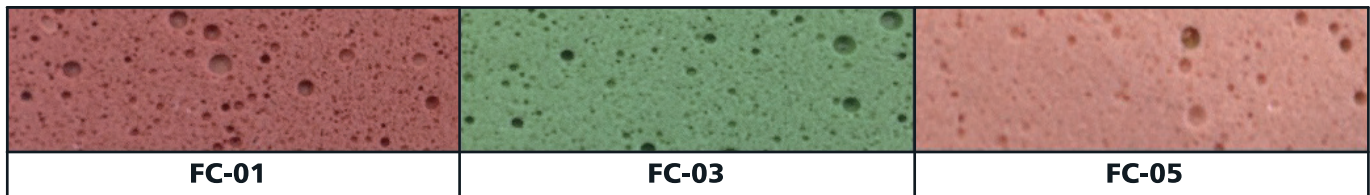

PU精密拋光皮

主要應用於精拋製程，其表面依照塗佈配方與發泡的溫度可區分為精緻型及粗糙型等種類，並依照背底基材可生產不用厚度的拋光墊，可搭配不同的拋光液使用，適合於：光電元件 (GaAs, Gap, InP, Sappihire, Si wafer等)、玻璃元件精拋、金屬元件精拋等，主要在精拋光製程中增進平坦度、去除刮傷的重要製程，並可搭配不同的SBR進行曲面玻璃拋光。

編號 Item	厚度 mm	壓縮率 %	密度 g/cm ³	開孔 um	硬度 Shore A	最大尺寸 mm	應用
TP-050	0.5	7.4	0.69	50~85	80	1000	藍玻璃粗精拋，玻璃類拋光、石英、壓力板墊襯底用。
TP-080	0.8	6	0.32	50~75	86	1350	藍玻璃粗拋、藍寶石類拋光、光學元件精拋、半導體元件精拋。
FS-120	1.2	8~11	0.34	60~80	68~75	1350	陶瓷、塑膠、金屬。
TP-150	1.5	3	0.40	50~60	68~75	1350	藍寶石類拋光、光學玻璃拋光、金屬類拋光、光學元件精拋。
FS-180	1.8	15	0.45	65~68	68	1350	藍玻璃、光學玻璃拋光、金屬類拋光、光學元件精拋。



Diamond & cBN Tools

各類磨棒/砂輪量身訂製

規格	顏色	應用
番號No. 顆粒尺寸(μm)	Color	Applications
#300000 0.05 (0-0.1)	紅·金色 Red·Golden	超精密拋光 Ultra-precision polishing <small>以上為非規格品</small> <small>詳細內容歡迎來電或洽詢現場業務人員</small>
#140000 0.1 (0-0.25)	藍·金色 Blue·Golden	
#60000 0.25 (0-0.5)	金色 Golden	
#28000 0.5 (0-1)	灰色 Grey	超鏡面拋光 Precision finishing
#14000 1 (0-2)	白色 White	
#8000 3 (2-4)	黃色 Yellow	
#5000 4.5 (3-6)	淺棕色 Light Brown	精密度拋光 Finishing
#3000 6 (4-8)	橙色 Orange	
#2000 8 (5-10)	淺紫色 Light Purple	
#1800 9 (6-12)	綠色 Green	
#1500 13 (10-16)	粉紅色 Pink	一般亮度用 Pre-polish lapping /Preparatory
#1200 15 (10-20)	藍色 Blue	
#1000 17.5 (15-20)	深綠色 Dark Green	
#800 25 (20-30)	咖啡色 Brown	
#600 35 (30-40)	紅色 Red	粗拋研削 Stock removal
#400 45 (40-50)	紫色 Purple	
#200 55 (50-60)	黑色 Black	

Diamond Grit Size Chart

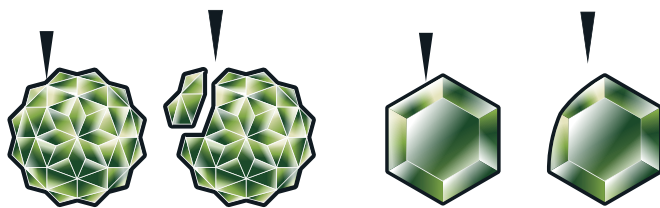

多晶 Polycrystalline

單晶 Monocrystalline

Differences
 Polycrystalline diamond consists of numerous small grains in a random structure. This gives the toughness in all directions resulting in less surface damage.
 *Ultra Fast Polishing
 *Better Surface Finishes
 *Self Sharpening Particles

- ◆ 相同粒號、工件材質、機器參數，多晶能更快實現理想拋光表面。
- ◆ 多晶鑽石微粉：球形多面體，銳口小。拋光時會逐漸崩裂成更小的晶體，產生新的銳口提供穩定的研磨力，表面細緻。
- ◆ 單晶鑽石微粉：晶體結構穩定、結晶面少、銳口深，容易造成表面產生較深的刮痕。拋光時單晶會逐漸鈍化，需要較長的研磨時間。
- ◆ 極大壓力下單晶較容易使工件內部殘存應力。



多晶 / 單晶鑽石粉 / 膏 / 液

Diamond Micron Powder/Compound/Slurry



多晶 / 單晶鑽石膏

DIAMOND COMPOUND

Polycrystalline / Monocrystalline Diamond Compound

圖片僅供參考，請以實物為準



鑽石膏說明
標準規格品為油性5公克，若需水溶性鑽石膏，請指明訂購。
Oil based, 5gram syringe is standard spec, custom package is also available upon request.
可使用的珠寶首飾及寶石，鋼鐵和硬金屬，鋁，鋅，冶金等材質上，
不建議使用在有鍍膜或有漆的表面上。
Can use on jewellery, gemstone, steel, hard metal, aluminium & zinc,
and all metallurgical purpose, not suitable for coating surface.

DIAMOND SLURRY

鑽石拋光液



Diamond Slurry

鑽石拋光液

單晶M. <input type="checkbox"/>	多晶P. <input type="checkbox"/>	油性O. <input type="checkbox"/>	水性W. <input type="checkbox"/>
0.5μm	1μm	3μm	6μm
9μm	Other		

宏崑實業有限公司
HONWAY MATERIALS CO., LTD.
+886-7-2231058 @ honwaygroup.com 聯繫客服
+886-7-2230658 service@honwaygroup.com

Polycrystalline Diamond Micron Powder

多晶鑽石粉



DIAMOND MICRON POWDER

Monocrystalline Diamond Micron Powder

單晶鑽石粉

NANO DIAMOND SLURRY 奈米鑽石拋光液



單晶 M. ■	多晶 P. ■	油性 O. ■	水性 W. ■		
100nm	300nm	500nm	800nm	1000nm	Other

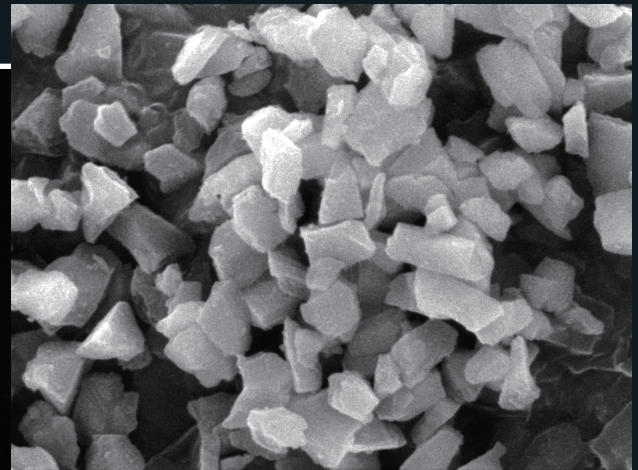

x25,000 10.0kV LED SEM WD 10.0mm 1µm

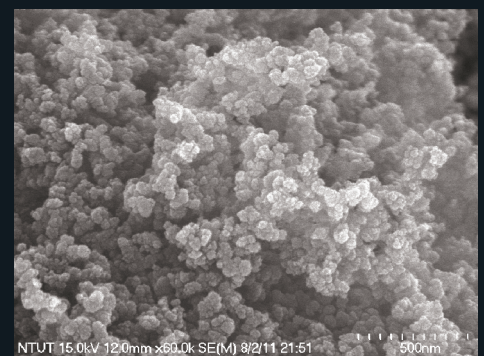

NTUT 15.0kV 120mm x60.0k SEM(M) 8/2/11 21:51 500nm

規格	
番號No.	顆粒尺寸(nm)
#500000	30
#300000	50
#150000	100
#50000	300
#30000	500
#20000	800
#15000	1000

球狀奈米鑽石微粉

球狀奈米鑽石微粉是在超高壓、高溫、瞬態條件下合成的。其構造是通過不飽和鍵結合的多晶顆粒，微晶尺寸僅3-10奈米，具良好的韌性。球狀奈米鑽石微粉結構與天然的多經黑鑽 (Carbonado) 相似，相較一般靜壓單晶鑽石微粉，能提供更細緻的研磨拋光性能。

球狀奈米鑽石製造工藝簡介

- 合成：在特定條件下，使優質石墨轉化為球狀奈米鑽石。
- 處理：通過萃取等方法除去殘存的石墨等雜質。
- 分級：特殊分級技術將混合微粉分成不同粒徑的分散體。
- 後處理：通過沉降、乾燥、包裝等作業完成。

結構特點

這種超細鑽石微粉呈各向同性，沒有解理面，因此不存在單晶鑽石微粉的容易沿解理面脆性斷裂的弱點。

性能特點

1. 使用壽命比較長。
2. 研磨過程中伴隨有奈米晶粒脫落，具有自銳性能。
3. 研磨拋光過程中沒有脆性斷裂，不易劃傷工件表面。

主要用途

晶圓、超精密模具、寶石、陶瓷以及合金的奈米級以及A埃級 (奈米級以下) 表面拋光。

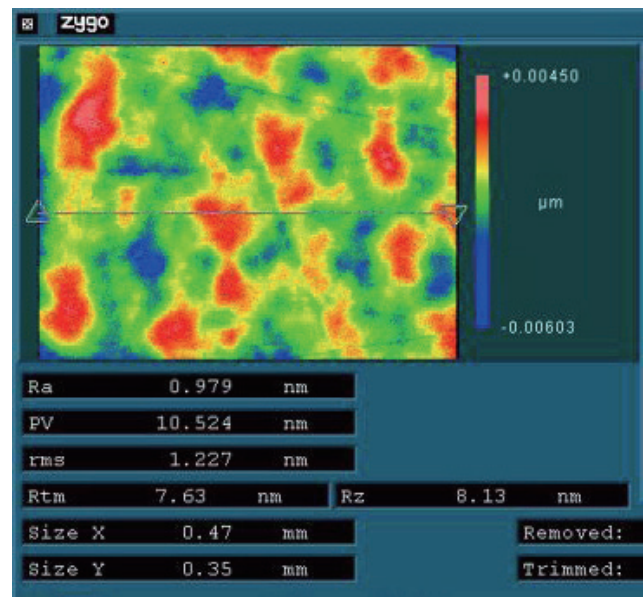

氧化鋁(鈾)拋光粉/膏/液 二氧化矽拋光液

Aluminum/Ce/SiO2 Oxide Powder/Paste/Slurry

氧化鋁拋光膏/粉/液

氧化鋁拋光膏 Alumina Polishing Paste

適用範圍:

各類金屬、精密模具、藍寶石、鋁合金、陶瓷等最終道拋光，建議做為一般鑽石膏後的表面清潔使用，球狀氧化鋁在工件上會有修復拋痕的功用，並擁有低成本優勢，可使拋光後的表面拋痕更佳，降低表面粗糙度，得到更亮潔的表面，建議使用粒度為最後使用的鑽石膏同等級粒度或是使用更細一階粒度使用，如有更高等級拋光表面需求，擇建議選用奈米鑽石系列產品。

顏色 (color)	顆粒尺寸 (um)
黃色 Yellow	0.3
蒂芬尼綠 Tiffany	0.5
紫色 Purple	1
紅色 Red	3



氧化鋁拋光粉/液 Alumina Powder / Alumina Polishing Slurry



氧化鋁拋光液



氧化鋁拋光粉

番號 No.	顆粒尺寸 (um)	應用 Application	氧化鋁拋光粉 Powder	氧化鋁拋光液 Polishing Slurry
#300000	0.05	超精密拋光 Ultra-precision polishing	●	●
#60000	0.3		●	●
#28000	0.5	超鏡面拋光 Precision finishing	●	●
#14000	1		●	●
#8000	3		●	●
#3000	5	精密度拋光 Finishing	●	●

氧化鈾拋光粉/液

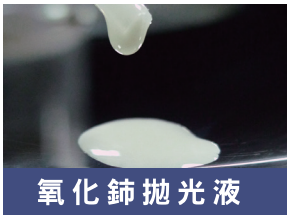

氧化鈾拋光液

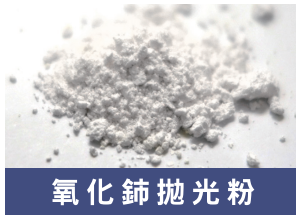

氧化鈾拋光粉

適用範圍:

各式玻璃划傷處理及玻璃油污清潔使用，玻璃若有除痕需求，請務必搭配工具並以低速拋磨，建議可搭配羊毛輪配合電動/氣動工具進行研磨修復，大面積如汽車擋風玻璃等亦可搭配打蠟機或震動拋光機使用，如只是去除油霧達撥水及亮潔效果，可使用羊毛輪或海綿徒手施作即可。

產品型號	產品狀態	顆粒尺寸 (um)	適用範圍與搭配拋光墊				
			一般青玻璃	白板光學玻璃	面板玻璃	光學元件	藍玻璃
RA-10	白色粉末狀	D50/0.8			●	●	
RA-08	白色粉末狀	D50/1.0		●	●	●	
RA-01	白色粉末狀	D50/1.5	●	●	●		
RA-12	白色粉末狀	D50/2.0	●				
HAT-1205	紅色粉末狀	D50/1.2				●	●
HAT-1805	紅色粉末狀	D50/1.8	●	●			
RGB-1935	拋光液	D50/0.5				●	●
RGB-1938	拋光液	D50/0.8				●	●

二氧化矽拋光液

適用範圍:

SO-80 是專為 LiTaO3、LiNbO3、藍寶石等電子材料基底、金屬材料及陶瓷的拋光而開發的高純度膠態二氧化矽拋光液。顆粒的均勻性、分散性好，能高效的獲得無損傷的研磨拋光面。

產品型號	產品狀態	顆粒尺寸 (um)	適用範圍
SO-80	拋光液	0.08	藍寶石 CaF2 BGO LiTaO3 LiNbO3

羊毛氈



彈性佳，配合性能好，組織緊密不易鬆散，耐磨。
可使用於工件拋光、保溫、絕緣、消音/隔音墊片等。

W x L x T 300x900x3

規格 Specifications

單位 Unit:mm

羊毛輪 Felt Bobs $\phi 6.0$ mm Shank

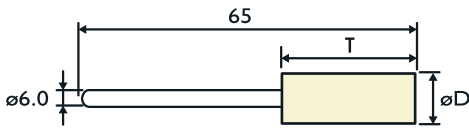

編號
Order no. ϕD T

	AC-1225A	12	25
	AC-1525A	15	25
	AC-2025A	20	25
	AC-2530A	25	30
	AC-1520C	15	20
	AC-2025C	20	25
	AC-2530C	25	30
	AC-3208E	32	8
	AC-4010E	40	9.6
	AC-1525K	15	25
	AC-2025K	20	25
	AC-2530K	25	30

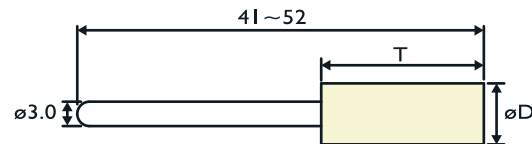

軸柄 Mandrel For Felt Disc

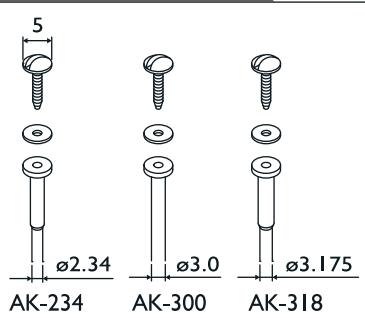

其他羊毛製品 Other Felt Products

羊毛條 Felt Stick

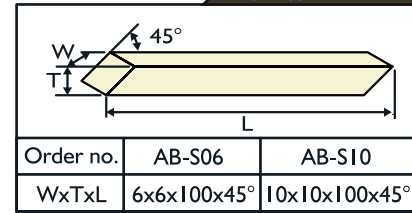

帶柄羊毛條 Mounted Felt Stick

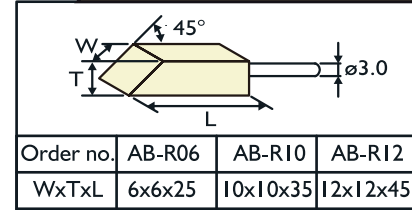

羊毛片 Felt Disc

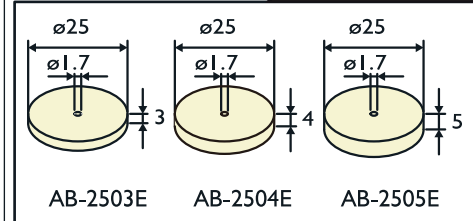

Felt Bobs- $\phi 3.0$ mm Shank

Order no.	AB-0410A	AB-0509A	AB-0610A	AB-0810A	AB-1014A	AB-1220A	AB-1520A
ϕD	4	5	6	8	10	12	15
T	8	9	10	10	14	20	20

Order no.	AB-2020A	AB-0408C	AB-0509C	AB-0610C	AB-0810C	AB-1013C	AB-1214C	AB-1220C	AB-0410J	AB-0512J	AB-0616J	AB-0817J	AB-1014J
ϕD	20	4	5	6	8	10	12	12	4	5	6	8	10
T	20	8	9	10	10	13	14	20	10	12	16	17	14

Order no.	AB-1020J	AB-1220J	AB-1225J	AB-08B	AB-10B	AB-12B	AB-18B	AB-1014R	AB-1225R	AB-1218T	AB-1218H	AB-0610K	AB-0814K	AB-1014K	AB-1220K
ϕD	10	12	12	8	10	12	18	10	12	12	12	6	8	10	12
T	20	20	25	-	-	-	-	14	25	18	18	10	14	14	20

貝斯迪亞® 纖維油石 & 迷你纖維油石

BESDIA® Ceramic Fiber Stones & Mini Ceramic Fiber Stones

	粒度 Grit Size 使用建議 Applications	
	#180 #250	模具放電加工後硬化表面層去除及機械切削粗糙刀痕之去除 To remove the rough machining surface or hard EDM scale of tool and die steels.
	#320 #400	細微加工痕跡之去除一般拋磨 General lapping of finer surface scratch line of tool & die steels.
	#700 #1000 #1200	精細研磨或鏡面處理前之拋光 Fine polishing & finishing.
	ø3.0mm 圓柱 Round	可搭配刻磨機當成研磨棒使用(長度勿超過50mm長), 亦或將之磨尖用於細微角落或夾縫處之研磨 It can be used like grinding point (max. length), or by sharpening it for detail lapping. 使用纖維油石時, 請將工具與工件成30°~40°, 端面研磨效果最佳 In order to reach the best performance, we recommend that the stone should be held up-right by making an angle of approx. 30°~45° to the work-piece.

全新的貝斯迪亞® 纖維油石, 採用精選陶瓷纖維以獨特的結合材料及製造方法, 有下列優點:

- 更好的抗折強度, 使用時更不易折斷。
- 相同的工作條件下, 增加10~20%以上的研磨效率。
- 大多數的工作條件下, 增加10~30%以上的研磨比。(工具壽命更長)

All New BESDIA® Ceramic Fiber Stone use the special ceramic fibers combined with the unique bonding material and manufacturing process. Compare to the previous one we sold:

- Our improvements in production processes give better tensile strength to the stones, hence fewer breakages.
- A polishing efficiency increase of 10% to 20% has been achieved.
- Durability under the same working conditions has been increased by 10% to 30%.

粒度與顏色 Grit Size & Color Code

粒度 Grit Size	#150	#180	#250	#320	#400	#700	#1000	#1200
顏色 Color	紫 Purple	咖啡色 Coffee	橙色 Orange	灰色 Grey	藍色 Blue	黃色 Yellow	白色 White	橘紅色 Red/Orange
代號 Code	P	C	O	G	B	Y	W	R

說明: #320灰色可取代舊有的#280黑色以及#360海軍藍
 Note: #320 Grey instead of #280 Black and #360 Navy Blue of old stones.

T x W x L (øD x L)	粒度與編號 Grit Size & Order No.							
	#150	#180	#250	#320	#400	#700	#1000	#1200
1x4x100	BSP-1004	BSC-1004	BSO-1004	BSG-1004	BSB-1004	BSY-1004	BSW-1004	BSR-1004
1x6x100	BSP-1006	BSC-1006	BSO-1006	BSG-1006	BSB-1006	BSY-1006	BSW-1006	BSR-1006
1x10x100	BSP-1010	BSC-1010	BSO-1010	BSG-1010	BSB-1010	BSY-1010	BSW-1010	BSR-1010
ø3.0x100	BGP-30	BGC-30	BGO-30	BGG-30	BGB-30	BGY-30	BGW-30	BGR-30

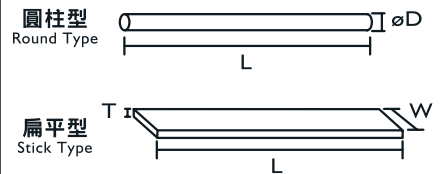

迷你纖維油石 Mini Ceramic Fiber Stones

Application Example

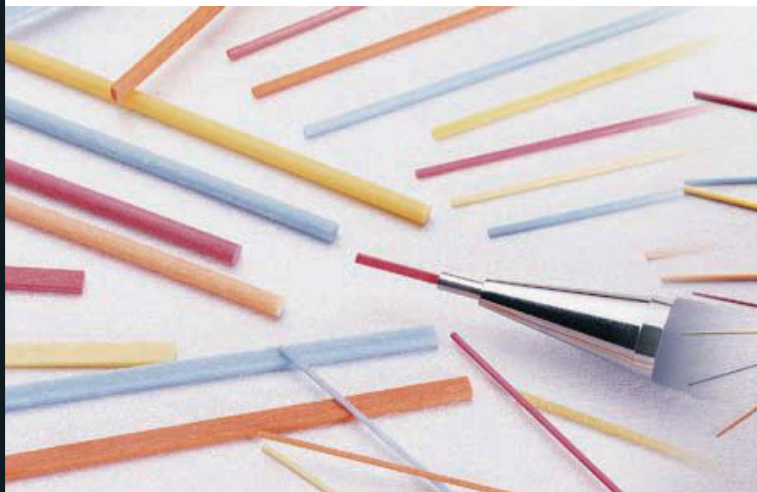
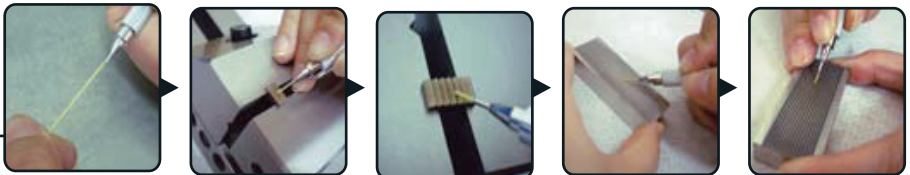

規格 Specifications				單位 Unit: mm	
尺寸 (mm) Dimensions (mm)	粒度與編號 Grit Size & Order No.			使用夾頭 Holder	
	#250	#400	#700	#1200	
0.5 x 0.5 x 50L	MOS-055	MBS-055	MYS-055	MRS-055	XH-007
0.7 x 0.7 x 50L	MOS-075	MBS-075	MYS-075	MRS-075	XH-009
0.9 x 0.9 x 50L	MOS-095	MBS-095	MYS-095	MRS-095	XH-013
1.0 x 2.0 x 100L	MOS-121	MBS-121	MYS-121	MRS-121	XH-200
ø0.9 x 50L	MOG-105	MBG-105	MYG-105	MRG-105	XH-009
ø2.0 x 100L	MOG-201	MBG-201	MYG-201	MRG-201	XH-200

迷你纖維油石是將纖維油石切成微細尺寸, 從0.5 x 0.5mm到1x2mm專門使用於各種模具之細微部位或是其他類似之加工由於陶瓷纖維具有高抗折強度, 可解決一般石油或紅寶石易斷的困擾

Mini Ceramic Fiber Stones are cut by ceramic fiber stone, their size from 0.5 x 0.5 mm to 1 x 2mm.

Ideal for various mold and dies detail lapping.

Traditional oil stone and ruby stones in such a small sizes are very easy to break, while mini ceramic stone provide high strength and high elasticity.

Due to its hard to break, they resolve the problem of using these stones.

用途

迷你纖維油石可適用於各種模具之研磨及各種零件之精細拋光尤其是雕刻部位之加工, 微小肋部, 模具角部精細拋磨, 以及各種微細或複雜部位之加工

Applications

It is good for all type of molds and dies fine and super fine finishing.

Especially for engraving parts, slight ribs, R ribs, corners, complicated area and details.

Besides, all other tool parts that needs details lapping, Our mini ceramic fiber stone will be the wonderful tools.

規格 Specifications

單位 Unit:mm

鑽石油石主要使用於各種刀具研磨後之刀部修磨，以延長刀具之壽命及提高加工物之表面光製度此外，亦適用於鎢鋼、陶瓷及硬化後鋼料之表面研磨。

Diamond Stone is considered as final finish for cutting tools. It is used to refine a surface by removing scratch lines and other surface imperfections. Therefore prolong the tool's life and smooth a surface finish. Also apply to lap the tungsten, ceramics and hardened steels.



尺寸 Dimensions W-(R)-X-L	柄部材質 Shank material	編號 Order no.
10-2-40	塑膠柄 Plastic shank	RSH-01
5-2-40	鐵柄 Steel shank	RSH-02
5-2.5R-4-40	鐵柄 Steel shank	RSH-03
10-2-30	鋁柄 Aluminum shank	RSH-04
10-3-120	-	RS-04
6-3-100	-	RS-05
4-4-100	-	RS-06
6-2-100	-	RS-08

鑽石油石
Diamond Stones

標準粒度 Grit size available:
#200, #400, #600, #800, #1000,
#1200, #1800, #2000, #3000, #5000.

訂購時，敬請指名產品編號與所需粒度 When ordering, please specify order no. & grit size.

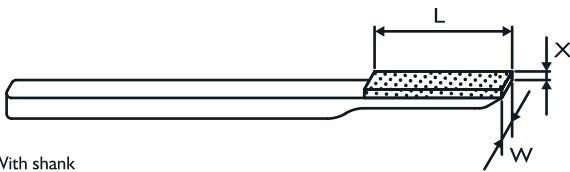

附柄型 With shank

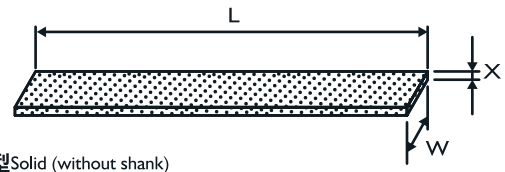

實心(無柄)型 Solid (without shank)

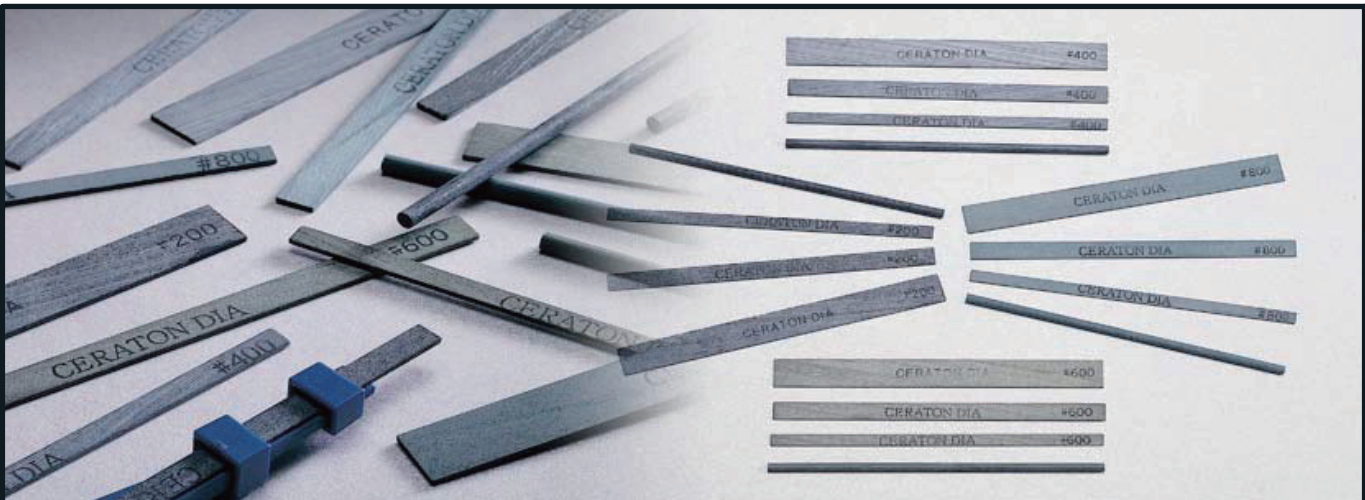

鑽石纖維油石
Ceramic Diamond Stones

鑽石纖維油石是將鑽石磨料與陶瓷纖維以熱固型樹脂結合而成由於鑽石優越的切削效果加上陶瓷纖維的高抗折強度結合成一個完美的拋磨工具
鑽石磨料均勻地分布在陶瓷纖維上
使超級鑽石油石任何面均可研削且加工面很均勻
如此可以減少後續的加工作業時間

In some special applications, ceramic cBN stones are also available, depend on your request. 其他粒度及尺寸亦可訂製在某些特殊的用途，氮化硼纖維油石亦可訂製，敬請指名訂購。

Ceramic diamond stones are made of diamond abrasives and ceramic fibers bonded together with thermosetting resin. Thanks diamond for its outstanding cutting performance in combination with the superior tensile strength of ceramic fiber, generates ceramic diamond stone, a perfect lapping tool. Diamond particles are sprayed on ceramic fibers for excellent uniform cutting action on every angle and therefore reduce after processing work.

特長

- 1.一般纖維油石只能用端面研削，而鑽石纖維油石任何面均有研磨效果
- 2.與樹脂鑽石油石比較，鑽石纖維油石有較佳的切削能力、不易塞目及不易折斷等優點
- 3.一些用一般纖維油石不易加工的材料，現在用鑽石纖維油石可以有有效的切削
- 4.鑽石纖維油石適用於加工所有熱處理後的鋼材、碳化鎢、陶瓷及玻璃等

Features

1. The ordinary ceramic fiber stone is efficient only to lap its end side or edge, while the ceramic diamond stone works well with any sides.
2. In comparison to the resinous diamond stones, ceramic diamond stone is more aggressive in cutting rate, resist loading, and hardly breaking.
3. Materials those are difficult to be ground by ordinary ceramic stone, now the ceramic diamond stone can provide a much better cut.
4. Ceramic diamond stone is ideal for lapping all kinds of hardened steels, EDM surface, tungsten carbide, ceramics and glasses efficiently.

規格 Specifications

單位 Unit:mm

	#200	#400	#600	#800
1x4x100	SDS-1042	SDS-1044	SDS-1046	SDS-1048
1x6x100	SDS-1062	SDS-1064	SDS-1066	SDS-1068
1x10x100	SDS-1102	SDS-1104	SDS-1106	SDS-1108
ø3x100	SDG-302	SDG-304	SDG-306	SDG-308

油石夾柄&油石&彈性帶柄砂輪

Tool Holders & Oil Polishing Stones & Elastic Mounted Points

編號Order No.	可挾持尺寸Holding Capacity	運用Applications
XH-007	Square 0.5 x 0.5 or Round ϕ 0.7	迷你纖維油石 For Mini Fiber Stone
XH-009	Square 0.7 x 0.7 or Round ϕ 0.9	迷你纖維油石 For Mini Fiber Stone
XH-200	Flat 2 x 1 or Round ϕ 2.0	迷你纖維油石 For Mini Fiber Stone
XH-013	Square 0.9 x 0.9 or Round ϕ 1.3	迷你纖維油石 For Mini Fiber Stone
XH-22	Round 3.0	纖維油石 For Fiber Stone
XH-041	平形 Flat 4 x 1	纖維油石 For Fiber Stone
XH-061	平形 Flat 6 x 1	纖維油石 For Fiber Stone
XH-101	平形 Flat 10 x 1	纖維油石 For Fiber Stone
XH-062	平形 Flat 6 x 2 ~ 6 x 3	一般油石 For Oil Stone
XH-133	平形 Flat 13 x 3	一般油石 For Oil Stone
XH-136	平形 Flat 13 x 6.3	一般油石 For Oil Stone

油石夾柄

Tool Holders

油石 Oil Polishing Stones

粒度 Grit size :
#120, #180, #220, #320,
#400, #600, #800, #1000.



W x T x L:
25 x 6 x 150, 25 x 3 x 150, 13 x 13 x 150,
13 x 6 x 150, 13 x 3 x 150, 13 x 1.6 x 150,
6 x 6 x 150, 6 x 3 x 150, 10 x 10 x 150.

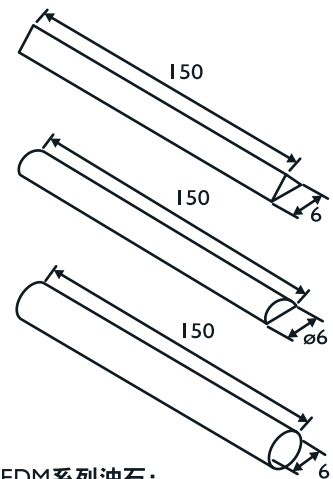
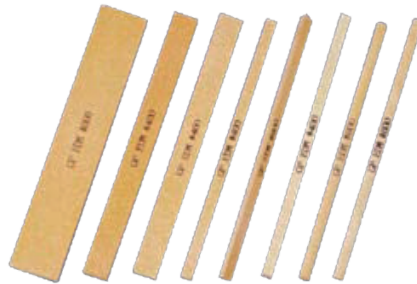

彈性帶柄砂輪 Elastic Mounted Points

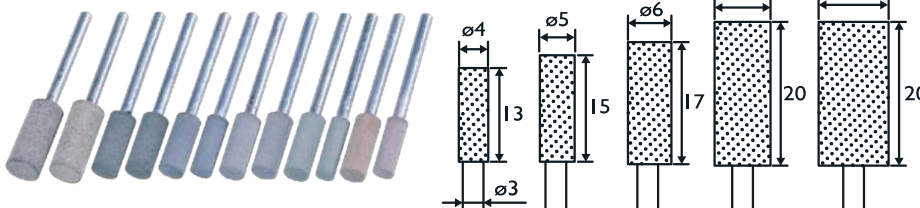

EDM系列油石：
主要用來去除各種模具EDM
加工後之硬化表層。
DF系列油石：
主要使用於一般模具機械加工之
痕跡去除及拋光作業。

EDM series stones are specially for removing the hard scale generated by the EDM process on all type of mold and die steels. DF series stones are suitable for removing the machined surface scratch and general lapping & polishing all mold and die steels.

規格 Specifications	粒度 Grit size	單位 Unit:mm				
牛皮砂輪 Resinoid point	#120	N413	N515	N617	N820	N1020
海綿砂輪 Rubberize point	#120	R413	R515	R617	R820	R1020

Elastic Mounted Points

規格 Specifications

單位 Unit:mm

木條

Lapping Wood Stick

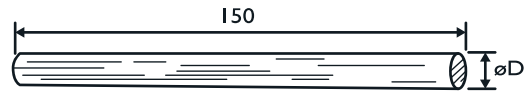

Order.no.	AFW-01H	AFW-02H	AFW-03H	AFW-04H
øD	ø3.2	ø4.7	ø6.4	ø9.5

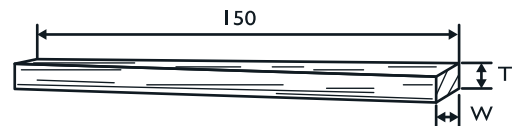

Order.no.	AFW-05H	AFW-06H	AFW-07H	AFW-08H
T x W	6.4 x 6.4	3.2 x 6.4	6.4 x 9.5	6.4 x 12.7

規格 Specifications

單位 Unit:mm

木棒

Wood Bobs

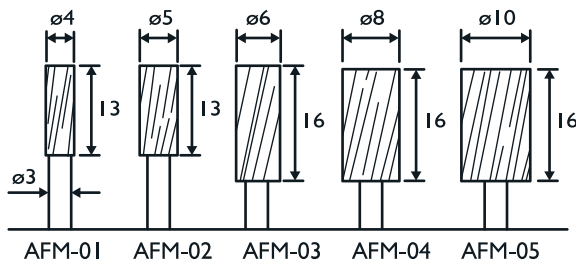

規格 Specifications

單位 Unit:mm

棕刷

Brush

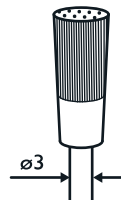

Order no.	AFB-01	AFB-02
øD	ø4.8	ø6.4

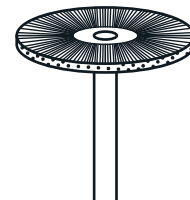

AFB-03	AFB-04
ø19	ø25.4

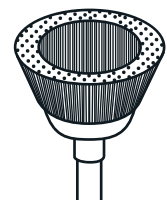

AFB-05	AFB-06
ø9/16"	ø1"

鑽石 · 氮化硼內孔磨棒

Diamond & CBN Internal Points

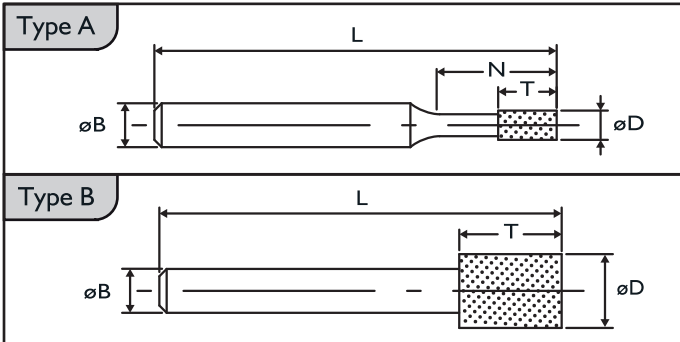

電鍍

Diamond internal points are used for jig, internal grinding, and precision grinding of small holes in carbide, ceramics, sapphire, glass etc. CBN internal points are used similarly on tough, high carbon, high chrome harden steels.

本系列產品主要使用於各種內孔研磨、
治具研磨或小孔徑之精密研磨
鑽石適用於研磨鎢鋼、陶瓷、藍寶石、玻璃等
氮化硼適用於研磨熱處理硬化後之各種合金鋼材

規格 Specifications		單位 Unit: mm						
編號 Order no.	Type	ϕD	T	N	L	ϕB	粒度 Grit size	
ID-3003	IB-3003	A	0.3	2	4	35	3.0	#600
ID-3004	IB-3004	A	0.4	2	5	35	3.0	#400
ID-3005	IB-3005	A	0.5	2	5	35	3.0	#400
ID-3006	IB-3006	A	0.6	3	5	40	3.0	#200
ID-3007	IB-3007	A	0.7	3	8	40	3.0	#200
ID-3008	IB-3008	A	0.8	3	8	40	3.0	#200
ID-3009	IB-3009	A	0.9	4	8	40	3.0	#200
ID-3010	IB-3010	A	1.0	5	8	40	3.0	#200
ID-3015	IB-3015	A	1.5	5	8	45	3.0	#150
ID-3020	IB-3020	A	2.0	5	12	45	3.0	#150
ID-3025	IB-3025	A	2.5	5	15	45	3.0	#150
ID-3030	IB-3030	A	3.0	5	15	45	3.0	#150
ID-3040	IB-3040	B	4.0	5	-	50	3.0	#150
ID-3050	IB-3050	B	5.0	8	-	50	3.0	#150
ID-3060	IB-3060	B	6.0	8	-	50	3.0	#150
ID-6040	IB-6040	A	4.0	10	22	80	6.0	#100
ID-6050	IB-6050	A	5.0	10	22	80	6.0	#100
ID-6060	IB-6060	A	6.0	10	22	80	6.0	#100
ID-6070	IB-6070	B	7.0	10	-	80	6.0	#100
ID-6080	IB-6080	B	8.0	10	-	80	6.0	#100
ID-6090	IB-6090	B	9.0	10	-	80	6.0	#100
ID-6100	IB-6100	B	10	10	-	80	6.0	#100
ID-6120	IB-6120	B	12	10	-	80	6.0	#100
ID-6140	IB-6140	B	14	10	-	80	6.0	#100
ID-6160	IB-6160	B	16	10	-	80	6.0	#100
ID-6180	IB-6180	B	18	10	-	80	6.0	#100

樹脂法

Resinoid CBN internal points are used for internal grinding and jig grinding of high speed steel and hardened alloy steel.

樹脂法CBN內孔磨棒主要使用於內孔研磨及治具研磨
氮化硼(CBN)適用於研磨高速鋼及各種熱處理硬化後之合金鋼材

規格 Specifications		單位 Unit: mm						
編號 Order no.	Type	ϕD	T	X	N	L	ϕB	粒度 Grit size
RIB-3040	A	4.0	5	1.0	12	45	3	#200
RIB-3045	A	4.5	6	1.25	12	45	3	#200
RIB-3050	A	5.0	6	1.5	12	45	3	#200
RIB-6060	A	6.0	6	2.0	15	80	6	#150
RIB-6070	A	7.0	8	2.5	15	80	6	#150
RIB-6080	A	8.0	8	3.0	20	80	6	#150
RIB-6100	A	10.0	10	2.0	20	80	6	#150
RIB-6120	B	12.0	10	3.0	-	80	6	#150
RIB-6140	B	14.0	10	4.0	-	80	6	#150
RIB-6160	B	16.0	10	4.0	-	80	6	#150
RIB-6180	B	18.0	10	5.0	-	80	6	#150
RIB-6200	B	20.0	10	6.0	-	80	6	#150

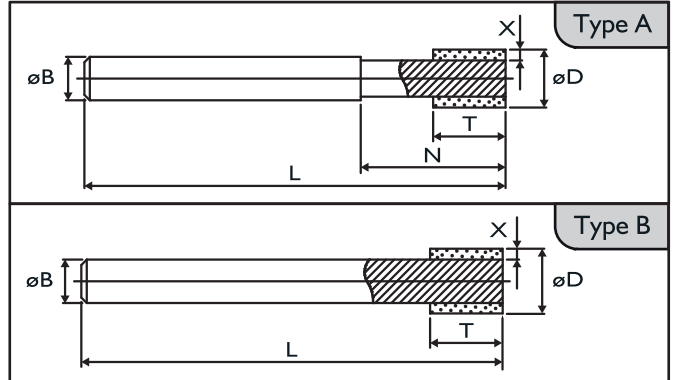

Vitrified CBN internal points are used for internal grinding and jig grinding of high speed steel and hardened alloy steel. (Wet Grinding)

陶瓷法

陶瓷法CBN內孔磨棒主要使用於內孔研磨及治具研磨
氮化硼(CBN)適用於研磨高速鋼及各種熱處理硬化後之合金鋼材(濕磨)

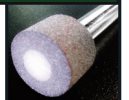

規格 Specifications		單位 Unit: mm						
編號 Order no.	Type	ϕD	T	X	N	L	ϕB	粒度 Grit size
VIB-3040	A	4.0	6	1.0	12	60	3	#200
VIB-3050	A	5.0	6	1.5	12	60	3	#200
VIB-3060	A	6.0	6	2.0	12	60	3	#200
VIB-3080	A	8.0	8	3.0	12	60	3	#200
VIB-6100	B	10.0	8	2.0	-	80	6	#200
VIB-6120	B	12.0	10	3.0	-	80	6	#200
VIB-8140	B	14.0	12	3.0	-	80	8	#200
VIB-6140	B	14.0	12	4.0	-	80	6	#200
VIB-8160	B	16.0	12	4.0	-	80	8	#200
VIB-6160	B	16.0	12	5.0	-	80	6	#200
VIB-8180	B	18.0	12	5.0	-	80	8	#200
VIB-6180	B	18.0	12	6.0	-	80	6	#200

標準粒度外，其他粒度請指明訂購

Grit size in the above table is standard for that item, others are available upon request.

規格 Specifications

單位 Unit:mm

BHS-10 BH Series- ϕ 2.34mm shank

Order no.	BH160E	BH60Q	BH60R	BH30A	BH25K	BH25J	BH25F	BH30V	BH15P	BH20B
ϕ D	16	6.0	6.0	3.0	2.5	2.5	2.5	3.0	1.5	2.0
T	0.5	10	14	15	10	10	6	(45°)	10	-
Grit size	#200	#100	#100	#120	#150	#150	#120	#200	#200	#150

套裝 10 支組，10 種磨棒各 1 支

BHS-30

Order no.	BH11A	BH14A	BH19A	BH24A	BH27A	BH32A	BH39A	BH49A	BH14R	BH24R	BH20B	BH24B	BH30B	BH35B	BH39B
ϕ D	1.1	1.4	1.9	2.4	2.7	3.2	3.9	4.9	1.4	2.4	2.0	2.4	3.0	3.5	3.9
T	7	7	7	7	7	7	10	10	10	13	-	-	-	-	-
Grit size	#150	#150	#120	#120	#120	#120	#120	#120	#150	#150	#150	#120	#120	#120	#120

Order no.	BH14C	BH19C	BH29C	BH39C	BH49C	BH18P	BH24P	BH29P	BH42P	BH14T	BH19T	BH26T	BH30S	BH30Y	BH17J
ϕ D	1.4	1.9	2.9	3.9	4.9	1.8	2.4	2.9	4.2	1.4	1.9	2.6	3.0	3.0	1.7
T	7	7	7	10	10	10	12	14	6	7	7	7	6	-	10
Grit size	#150	#120	#120	#120	#120	#150	#150	#150	#150	#120	#120	#120	#120	#150	#150

套裝 30 支組，30 種磨棒各 1 支

BHS-20 套裝 20 支組，含以上有 * 標示之磨棒各 1 支 20 pcs. set, contains one each of points which denoted by *.

規格 Specifications

單位 Unit:mm

BH Series- ϕ 2.34mm shank

Order no.	D1	D2	D3	D4	A11	A12	A13	A21	A30	7A	8A	C3	CI3	C23	TR	IR	KS	ILR	2R	2LR	3R	5R	6R	7R	8R	K6	K10	KA
ϕ D	1	2	3	4	1	1.5	1.5	2.5	3	7	8	0.9	1.5	2	1.5	1.5	3.5	1.5	2	2.5	3	4	5	7	8	2	2.5	7
T	-	-	-	-	5	5	7	7	7	6	10	4	10	10	8	10	6	10	12	12	12	12	12	12	12	5	7	12

Order no.	I2BA	I4BA	I6BA	I9BA	T11	T12	T13	T30	IA	2A	2LA	3A	5A	6A	RZ	2LB	A14	Kr5	Kr8	Kr9	A20	A31	I0B	I2B	I3B	I4B
ϕ D	4	6	10	12	1	1.5	2	3	2	2.5	2.5	3	4	5	4	2.5	2.5	6	8	8	2.5	3	2.7	4	5	6
T	-	-	-	-	4	4	4	4	8	12	10	10	10	10	6	12	7	1.5	2	3	7	7	-	-	-	-

Order no.	I6B	I6BB	I6BC	I3nk	I3mB	I6mC	I6mB	RT	I0X	I7X	I8X	I9X	23X	I0BN	I2BN	I3BN	I0mA	I3mA
ϕ D	10	10	10	5	13	16	16	5	1.8	4	6	10	16	2.5	4	5	10	13
T	-	-	-	-	2.5	2.5	3.5	7	0.5	0.8	1	1.6	2	-	-	-	2.5	3.5

Order no.	I6mA	K25	K30	K35	K45	K50	K55	K60	20mA	88D	88C	88A
ϕ D	16	4	5	6	10	10	12	12	20	22	22	22
T	3.5	0.4	0.6	0.5	0.5	1	0.6	1	3.5	0.45	0.35	0.45

客製品單一規格最低訂購量 10 支，約 20 個工作天

鑽石磨棒 & 綜合組裝

Diamond Mounted Points & Assortment set

規格 Specifications

單位 Unit:mm

BM Series- ϕ 3.0mm shank

BMS-30

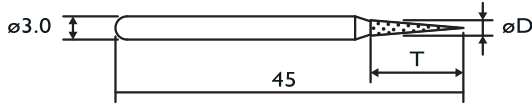

30 pieces assortment set, contains one each point which denoted by *.

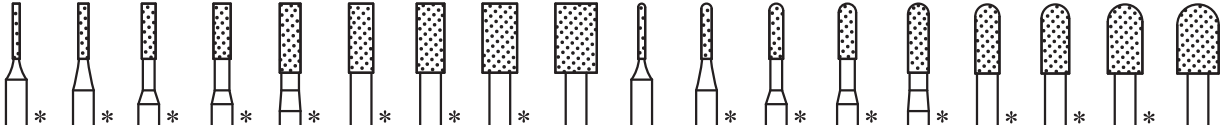

Order no.	10A	15A	20A	25A	30A	35A	40A	50A	60A	10C	15C	20C	25C	30C	35C	40C	50C	60C
ϕ D	1	1.5	2	2.5	3	3.5	4	5	6	1	1.5	2	2.5	3	3.5	4	5	6
T	8	8	8	8	10	10	10	10	10	8	8	8	8	10	10	10	10	10
Grit size	#150	#150	#120	#120	#120	#120	#120	#100	#100	#150	#150	#120	#120	#120	#120	#120	#100	#100

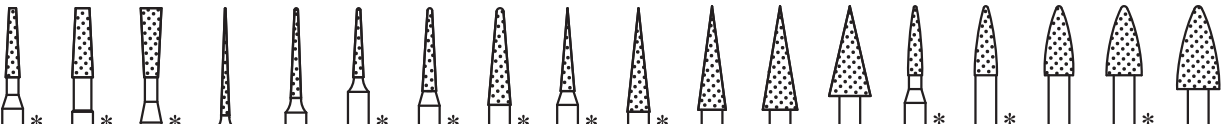

Order no.	20T	30T	30V	13R	14R	15R	20R	30R	20P	30P	40P	50P	60P	20F	30F	40F	50F	60F
ϕ D	2	3	3	1.2	1.5	1.5	2	3	2	3	4	5	6	2	3	4	5	6
T	10	10	10	16	13	10	12	14	12	15	15	15	13	10	12	10	10	12
Grit size	#120	#120	#120	#150	#150	#150	#150	#120	#150	#150	#150	#150	#150	#120	#120	#120	#100	#100

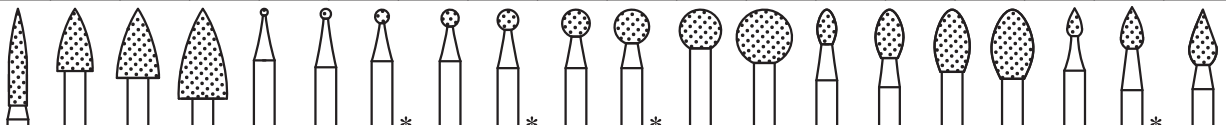

Order no.	30J	40J	50J	60J	10B	15B	20B	25B	30B	40B	50B	60B	80B	30Q	40Q	50Q	60Q	20S	30S	40S
ϕ D	3	4	5	6	1	1.5	2	2.5	3	4	5	6	8	3	4	5	6	2	3	4
T	14	9	10	13	-	-	-	-	-	-	-	-	-	5	7	9	10	4	6	8
Grit size	#120	#120	#120	#100	#200	#150	#150	#120	#120	#120	#100	#100	#100	#120	#120	#100	#100	#120	#120	#120

30支綜合組裝，含此表格有標示*記號磨棒各一支

Assortment set

綜合組裝

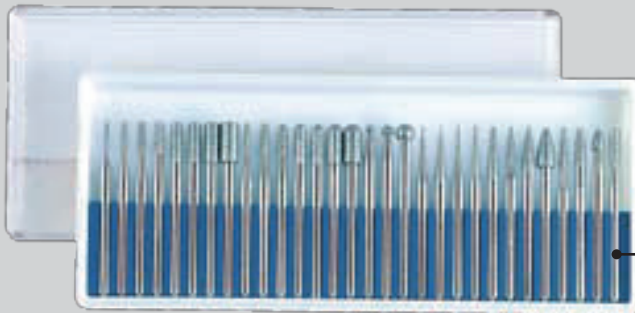

BMS-30: 30支組 30pcs.set

BM-10A、15A、20A、25A、30A、35A、40A、50A、20B、30B、50B、15C、20C、25C、30C、35C、40C、50C、20P、30P、15R、20R、30R、30S、20F、30F、50F、20T、30T、30V. (各一支)

所有BM系列磨棒均可以改成 ϕ 1/8"柄，請指明訂購 BLS-30及BLS-20為標準庫存品之 ϕ 1/8"柄磨棒，其內容物與BMS-30及BMS-20相同，只有柄徑不同

Shank measure 1/8" in diameter is available upon request.

BL series are ϕ 1/8" shank with all shapes and sizes the same as BM series.

BLS-30 and BLS-20 are standard assortment set stock available for ϕ 1/8" shank, contains the same type of points as BMS-30 and BMS-20.

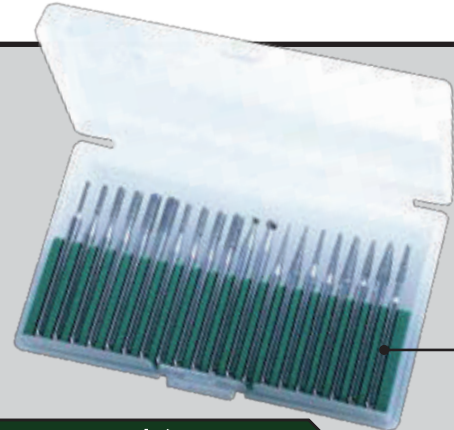

BMS-20: 20支組 20pcs.set

BM-10A、15A、20A、25A、30A、35A、15C、20C、25C、30C、20P、30P、15R、20R、30R、20B、30B、20F、30F、20T. (各一支)

BL系列: ϕ 1/8"柄 BL Series: ϕ 1/8"Shank

BLS-30:30支組 BLS-30:30pcs.set

BLS-20:20支組 BLS-20:20pcs.set

規格 Specifications

單位 Unit:mm

BC Series- $\phi 6.0$ mm shank

粒度: #40, #60, #100 為標準粒度, 訂購時請指明

例如: BC-65A, #40

柄徑: $\phi 6.0$ mm, 全長: 60~65mm

Grit size available in #40, #60 and #100, When ordering, please specify.

Ordering example: BC-65A, #40

Shank diameter: $\phi 6.0$ mm, Total length: 60~65mm.



BC-10 套裝 10 支組, 含標示 * 號之磨棒各 1 支。訂購時請指明粒度。

65A	80A*	101A	100A	102A	180A	80B*	100B	160B	200B	65C*	80C	100C	60C	100E*	65F*

70F	80F*	100F	100J	60P	61P	80P*	100P	60Q	90Q	100Q	120Q	100N	140PR

160PR	65R*	80T*	250U	80V*	80VB	165Y	200Y	250Y	250X

BC-10 : 10 pcs. Assortment set, contains one each of above points, which denoted by *. Ordering example : BC-10/#60

規格 Specifications

單位 Unit:mm

Diamond Taper Points

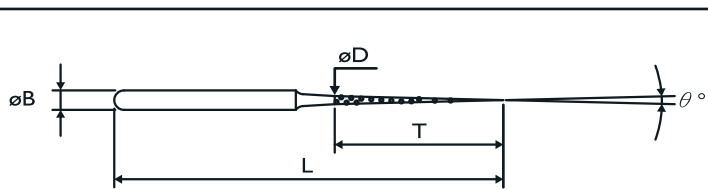

編號 Order no.	φD	T	θ°	L	φB	粒度 Grit size
18PL	φ1.8	25	3.1	50	φ3.0	#150
21PXL	φ2.1	34	2.8	55	φ3.0	#150
30PL	φ3.0	25	6.4	60	φ3.0	#150
48PL	φ4.8	26	9.6	55	φ3.0	#150
15PL	φ1.5	26	2.3	60	φ3.0	#150
20PXL	φ2.0	48	1.9	70	φ3.0	#150
23PXL	φ2.3	40	2.7	65	φ3.0	#150
25PXL	φ2.5	45	2.6	70	φ3.0	#150
30PXL	φ3.0	38	4.2	70	φ3.0	#150
60P10	φ6.0	33	10	60	φ6.0	#120
60P12	φ6.0	28	12	60	φ6.0	#120
60P14	φ6.0	23	14	60	φ6.0	#120
60P16	φ6.0	21	16	60	φ6.0	#120
60P20	φ6.0	17	20	60	φ6.0	#120
100P30	φ10.0	19	30	60	φ6.0	#120

客製鑽石磨棒 & 穿孔磨棒

Customized Products & Diamond Internal Boring Files

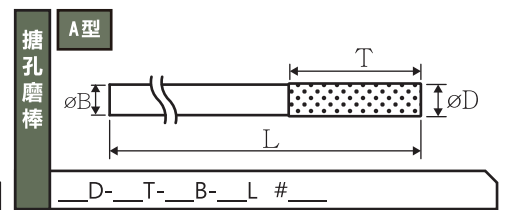
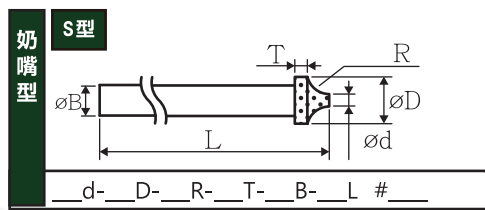
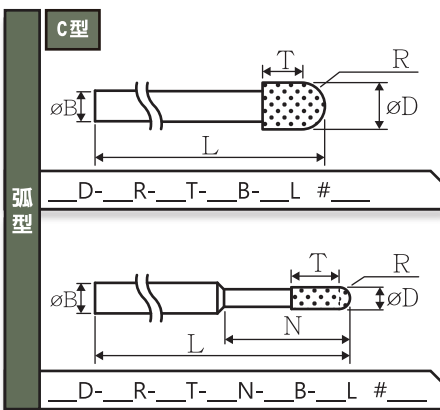
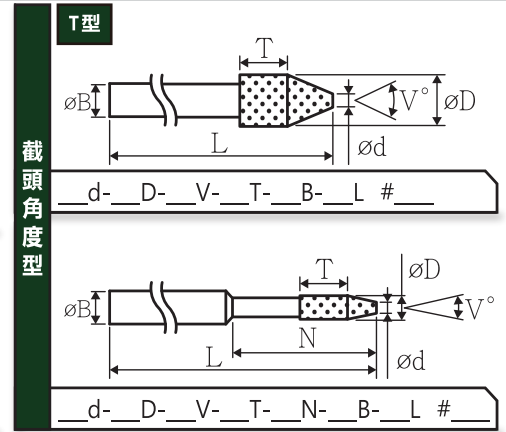
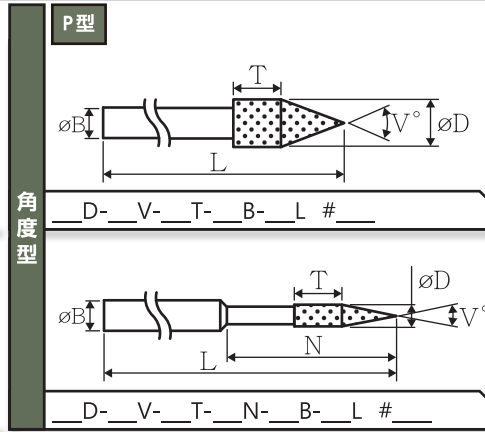
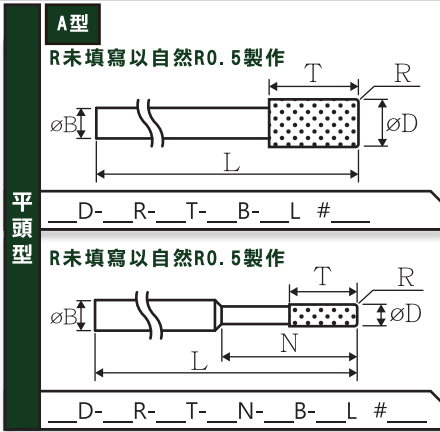

客製化鑽石磨棒

Customized Products

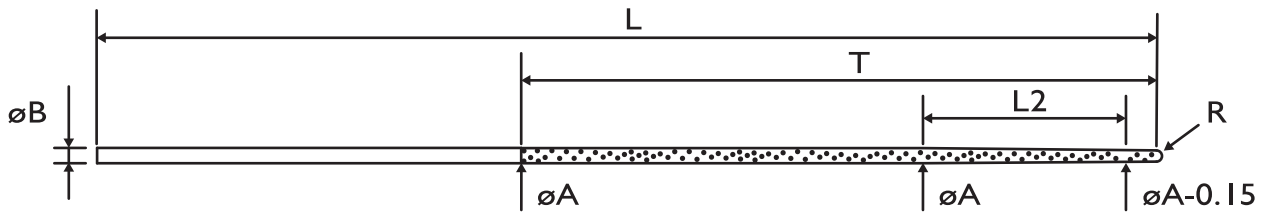

規格 Specifications

單位 Unit:mm

ϕA O. D	ϕB Shank	ϕA O. D	ϕB Shank	ϕA O. D	ϕB Shank	ϕA O. D	ϕB Shank	ϕA O. D	ϕB Shank	ϕA O. D	ϕB Shank	ϕA O. D	ϕB Shank
1.0	0.70	2.0	1.70	3.0	2.70	4.0	3.70	5.0	4.60	6.0	5.60	7.0	6.70
1.1	0.80	2.1	1.80	3.1	2.80	4.1	3.70	5.1	4.70	6.1	5.80	7.1	6.80
1.2	0.90	2.2	1.90	3.2	2.90	4.2	3.80	5.2	4.80	6.2	5.90	7.2	6.90
1.3	1.00	2.3	2.00	3.3	3.00	4.3	3.90	5.3	4.90	6.3	6.00	7.3	7.00
1.4	1.10	2.4	2.10	3.4	3.10	4.4	4.00	5.4	5.00	6.4	6.10	7.4	7.10
1.5	1.20	2.5	2.20	3.5	3.20	4.5	4.10	5.5	5.10	6.5	6.20	7.5	7.20
1.6	1.30	2.6	2.30	3.6	3.30	4.6	4.20	5.6	5.20	6.6	6.30	7.6	7.30
1.7	1.40	2.7	2.40	3.7	3.40	4.7	4.30	5.7	5.30	6.7	6.40	7.7	7.40
1.8	1.50	2.8	2.50	3.8	3.50	4.8	4.40	5.8	5.40	6.8	6.50	7.8	7.50
1.9	1.60	2.9	2.60	3.9	3.60	4.9	4.50	5.9	5.50	6.9	6.60	7.9	7.60
												9.0	8.70

ϕA O. D	斜面長 L2 Taper Length	T Plated Length	L Total Length	粒度 Grit size
1.0~1.4	50	80	150	D100
1.5~7.0	90	120	200	
7.1~9.0	80	120	250	

鑽石穿孔磨棒

Diamond Internal Boring Files

正確安裝及使用 Installation and operation

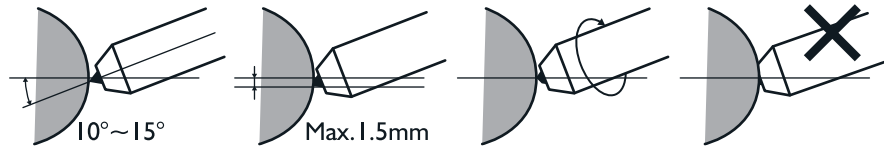

單石修刀

Single Point Diamond Dressers



鑽石番號 Dia. wt. code	大約重量(克拉) Approx. wt.(cts.)	編號 Order no.	適用砂輪 Grinding wheels size(mm)
#5	0.18	DS005	ø150x25以下 or smaller
#10	0.20	DS010	
#15	0.25	DS015	
#20	0.35	DS020	ø150~ø300x25
#25	0.50	DS025	
#33	0.75	DS033	
#50	1.0	DS050	
#75	1.5	DS075	ø450~ø600x50~100
#100	2.0	DS100	ø600以上 or larger.

成型修刀 Chisel Type Diamond Dressers

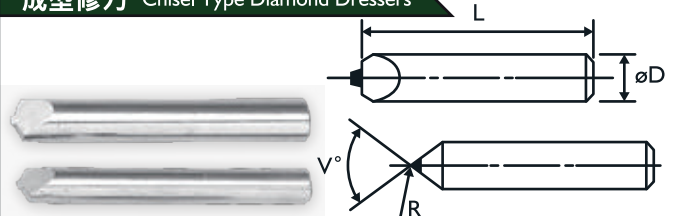

成型修刀用於砂輪之成形修整，或內、外弧之成形修整
For forming accurate radii and forms on grinding wheels.

鑽石角度(V°)	鑽石端弧度(R)	鑽石原料 Diamond material	編號 Order no.
55°	0.2 R	天然鑽石 Nature Diamond	DF0255
60°	0.5 R		DF0560
55°	0.2 R	人造鑽石 Synthetic Diamond	DF0255F
60°	0.5 R		DF0560F

圓錐修刀 Coned Diamond Dressers

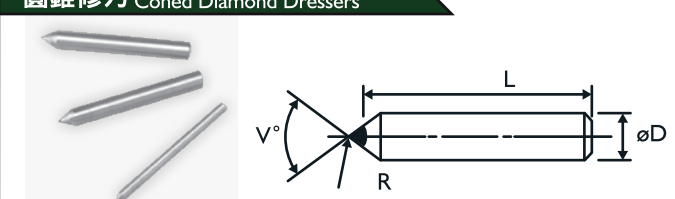

圓錐修刀用於砂輪之成形修整，或內、外弧之成形修整
For forming accurate radii and forms on grinding wheels.

鑽石角度(V°)	鑽石端弧度(R)	鑽石原料 Diamond material	編號 Order no.
60°	0.02~0.03R	ø1/8"x1"L	DC600
60°	0.02~0.03R	ø1/8"x2"L	DC601
60°	0.02~0.03R	ø1/4"x2"L	DC602
60°	0.02~0.03R	ø3/8"x2"L	DC603
60°	0.02~0.03R	ø10 x 50L(mm)	DC604

CVD成型修刀 CVD Forming Dressers

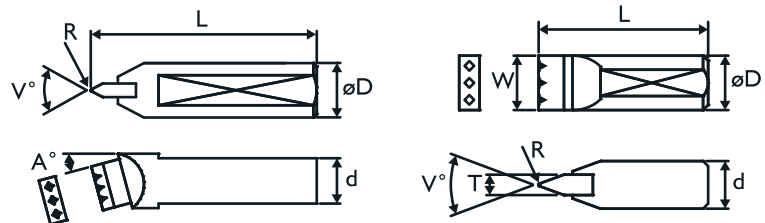

V°	A°	W	R	øD	d	L	鑽石顆數 Stone nos.	編號 Order no.
40	-	8	0.2	8	-	25	3	CVD-F0240-I
55	-	10	0.2	12	11	40	3	CVD-F0255-I
55	15	10	0.2	12	10	50	3	CVD-F02550-T1
55	6	10	0.2	12	11.5	50	3	CVD-F02550-T2

訂購時請說明編號及鐵柄尺寸或提供詳細圖面

When ordering, please specify order no. & shank size or detail drawing.

結合修刀

Impregnated Diamond Dressers



鑽石齒塊尺寸 The dimensions of diamond tips

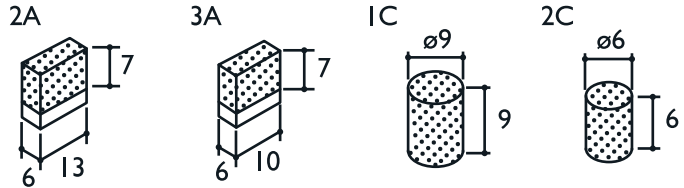

編號 Order no.	鑽石齒塊 Diamond tips	粒度 Grit size	鐵柄形狀 Type of shank	鐵柄尺寸 Size of shank	適用範圍 Applications
DI-2AFC	2A	F		$\phi 12 \times 100L$ $\phi 12 \times 50L$ $\phi 11 \times 30L$	無心研磨, 圓筒研磨, 平面研磨砂輪尺寸 $\phi 300 \times 25$ 到 $\phi 500 \times 63$ For centerless, cylindrical, surface grinding. Wheel size : $\phi 300 \times 25$ to $\phi 500 \times 63$
DI-2AMC	2A	M			
DI-2ARC	2A	R			
DI-2AFD	2A	F			
DI-2AMD	2A	M			
DI-2ARD	2A	R			
DI-1CFG	1C	F		$\phi 12 \times 50L$ $\phi 11 \times 30L$	一般用途之研磨砂輪尺寸 $\phi 300$ 或以下 For general purpose grinding. Wheel size: $\phi 300$ and smaller.
DI-1CMG	1C	M			
DI-1CRG	1C	R			

粒度 Grit size: F:細目Fine M:中目Medium R:粗目Coarse

艾瑪合金

Molybdenum Rod



具有高強度、抗磨損的優異性能，常用於修整大規格的砂輪、鑽石砂輪、還有CBN砂輪，另外此款材料具有高融點、良好的導熱率和低的熱膨脹性能。

在高溫下可以抗氧化、強度高，此款合金修整出來的砂輪表面品質好，修整時間縮短，修整間隔增長，大幅提高生產效率及品質。



ϕD	L
$\phi 10$	50
$\phi 12$	
$\phi 16$	
$\phi 18$	

如需客訂請洽業務人員

聚晶鑽石和聚晶氮化硼車刀與其他切削刀具比較，具有較高之硬度及耐磨耗性，其優點如下：
有較長之刀具壽命，提高工件加工精度及表面光製度，降低工件加工成本以及提高機器生產力

PCD & PCBN have higher hardness & abrasion resistance than other cutting tools The advantages of these features are :
improving tools life, providing better control over part size and surface finishes,
reducing tool cost per machined part and improving machine productivity.

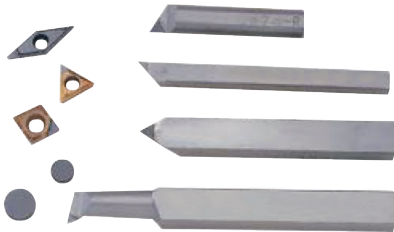

應用範圍：
聚晶鑽石(PCD)
銅合金、鋁合金
燒結碳化鎢及陶瓷
預燒結碳化鎢及陶瓷
高矽鋁合金
F.R.P、硬橡膠、石墨
聚晶氮化硼(PCBN)
硬化鋼材(HRC 45~ 68)
耐熱鋼(SUS)
超耐熱鋼：鎳基合金、鈷基合金
鑄鐵：冷激鑄鐵、接種鑄鐵
燒結合金鋼：鉻鉬鋼、鎳鉻鉬鋼

Applications :
Polycrystalline Diamond (PCD)
Aluminum alloys、copper alloys、manganese alloys
Sintered carbide & ceramics
Green or semi-sintered carbide & ceramics
High-silicon aluminum alloys
Reinforced plastic、hard rubber、carbon、graphite
Polycrystalline Cubic Boron Nitride (PCBN)
Hardened steels (HRC 45 ~ 68) Tempering steels
Super alloys:
Cobalt and nickel base super alloys
Cast iron:
Chilled iron,
Meehanite iron
Sintered ferrous alloys:
SCM, SNCM

規格 Specifications

單位 Unit:mm

31 型

編號 Order no.	刀片材質 Tip material	W	H	L	R	V°	S
B4612-4G	PCBN	16	16	120	0.4	0	0
B4613-4G	PCBN	19	19	140	0.4	0	0

編號 Order no.	刀片材質 Tip material	W	H	L	R	V°	S
D6732-5B	PCD	16	16	120	0.5	0	0
D6733-5B	PCD	19	19	140	0.5	0	0
B6630-4G	PCBN	10	10	80	0.4	0	0
B6631-4G	PCBN	13	13	100	0.4	0	0
B6632-4G	PCBN	16	16	120	0.4	0	0
D6530-3F	PCD	10	10	80	0.3	10	0
D6531-3F	PCD	13	13	100	0.3	10	0
D6532-3F	PCD	16	16	120	0.3	10	0

33 型

34 型

編號 Order no.	刀片材質 Tip material	W	H	L	R	V°	S
D6540-3F	PCD	10	10	80	0.3	10	0
D6541-3F	PCD	13	13	100	0.3	10	0
D6542-3F	PCD	16	16	120	0.3	10	0

編號 Order no.	刀片材質 Tip material	W	H	L	R	V°	S
D6752-5B	PCD	16	16	120	0.5	0	0
D6753-5B	PCD	19	19	140	0.5	0	0
B6650-4G	PCBN	10	10	80	0.4	0	0
B6651-4G	PCBN	13	13	100	0.4	0	0
B6652-4G	PCBN	16	16	120	0.4	0	0
D6550-3F	PCD	10	10	80	0.3	10	0
D6551-3F	PCD	13	13	100	0.3	10	0
D6552-3F	PCD	16	16	120	0.3	10	0

35 型

37 型

編號 Order no.	刀片材質 Tip material	W	H	L	R	V°	S
D6772-5B	PCD	16	16	120	0.5	0	2
D6773-5B	PCD	19	19	140	0.5	0	2
B6672-4G	PCBN	16	16	120	0.4	0	2
B6673-4G	PCBN	19	19	140	0.4	0	2
D6571-3F	PCD	13	13	100	0.3	10	2
D6572-3F	PCD	16	16	120	0.3	10	2

Note: The turning tools with other specification, please offer detail drawing when ordering.

說明: 其他規格之車刀, 請提供詳細圖面訂購

鑽石銼刀片

Diamond Tip Files

規格 Specifications

單位 Unit:mm

L	T	形狀 Cross-section	粒度 Grit size	編號 Order no.
60	25	4~2 1.0~0.5	#150 #200 #400	* FA-426J * FA-426F FA-426V
60	25	4 1.0~0.5	#150 #200 #400	* FA-446J * FA-446F FA-446V
70	40	6 1.0~0.5	#150 #200 #400	* FA-667J * FA-667F FA-667V
70	40	8 1.0~0.5	#150 #200 #400	FA-887J FA-887F FA-887V
90	60	8 1.0~0.5	#150 #200 #400	* FA-889J * FA-889F FA-889V
70	40	10 1.0~0.5	#150 #200 #400	FA-107J FA-107F FA-107V
90	60	10 1.0~0.5	#150 #200 #400	* FA-109J * FA-109F FA-109V
60	25	3~2 1.0~0.5	#200 #400 #600	FA-326F FA-326V FA-326X
60	25	4~3 1.0~0.5	#200 #400 #600	FA-436F FA-436V FA-436X
70	40	3~2 1.0~0.5	#200 #400 #600	FA-327F FA-327V FA-327X
70	40	4~3 1.0~0.5	#200 #400 #600	FA-437F FA-437V FA-437X
(122)		1.0		XH-12

FAS-100T

特點:

1. 高彈性，可彎曲研磨
2. 厚度只有1mm，適合夾縫研磨
3. 適合用於各種銼磨機及手持加工

Features:

1. With the maximum thickness of 1mm only, the files are suitable for narrow and deep gap processing. Contoured to make difficult-to-reach areas readily accessible.
2. They are tapered in thickness to make possible perfectly flat filing and flexible for bending while still maintaining their hardness.
3. Both suitable for hand-held and machine-mounted operations.

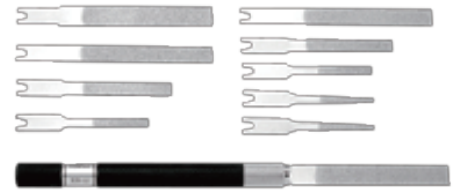
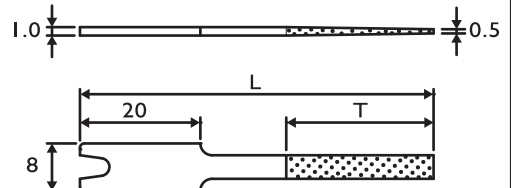

10pcs. Set with tool holder / wooden case, containing one each of file which denoted by asterisk and one tool holder (XH-12).

10支組木盒裝，含夾柄1支及有★標示之銼刀各1支。

規格 Specifications

單位 Unit:mm

FAS-600

L	T	形狀 Shape	粒度 Grit size	編號 Order no.
70	40	2~3 1.4~0.5	#150 #200 #400 #600	FA-632J FA-632F FA-632V FA-632X
80	50	4~3 1.4~0.5	#150 #200 #400 #600	FA-643J FA-643F FA-643V FA-643X
90	50	6 1.4~0.5	#150 #200 #400 #600	FA-666J FA-666F FA-666V FA-666X
90	50	8 1.4~0.5	#150 #200 #400 #600	FA-688J FA-688F FA-688V FA-688X
(122)		1.5 1.0		XH-32

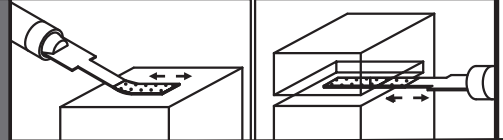

特點:

1. 節省材料
2. 配合夾柄(XH-32)使用，手感更好
3. 全新製程，切削力及壽命更好
4. 可手持操作，亦可夾於機器上使用
5. 銼刀形狀設計更合乎人體工學
6. 可取代一般鑽石平斜銼刀

Features:

1. Less material usage.
2. The usage of holder (XH-32) makes it feel much better when operating.
3. Brand-new manufacturing process provides a better cutting ability and also prolongs the tool life.
4. Both suitable for hand-held and machine-mounted operations.
5. The designation is complied with the ergonomic.
6. Be able to replace the general diamond tapered hand files.

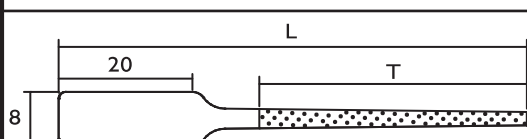

BF-90



• Total length: 140mm
• Tool shank: $\phi 3.0$ mm
• Diamond coating length: 20mm

全長: 140mm 柄徑: $\phi 3.0$ mm 鑽石長: 20mm

形狀 · 尺寸 Shape · Size(mm)	#150	#200	#400
1. 6x1.3	BF-901	BF-901F	BF-901V
2. 2.5	BF-902	BF-902F	BF-902V
3. 3.5x1.5	BF-903	BF-903F	BF-903V
4. 3.5	BF-904	BF-904F	BF-904V
5. 5x2	BF-905	BF-905F	BF-905V
6. 3.5x1.5	BF-906	BF-906F	BF-906V
7. 3.5x2	BF-907	BF-907F	BF-907V
8. $\phi 3$	BF-908	BF-908F	BF-908V
9. 5x1.5	BF-909	BF-909F	BF-909V
10. $\phi 2.3$	BF-910	BF-910F	BF-910V
套裝 10支組 10 pcs.set	BF-900	BF-900F	BF-900V

BF-60



• Total length: 140mm
• Tool shank: $\phi 3.0$ mm
• Diamond coating length: 30mm

形狀 · 尺寸 Shape · Size(mm)	#150	#200	#400
1. 5.5x1.2	BF-601	BF-601F	BF-601V
2. 5x2	BF-602	BF-602F	BF-602V
3. $\phi 3$	BF-603	BF-603F	BF-603V
4. 2.5	BF-604	BF-604F	BF-604V
5. 3.5	BF-605	BF-605F	BF-605V
★ 套裝 5支組 5 pcs.set	BF-600	BF-600F	BF-600V

BF-80



• Total length: 155mm
• Tool shank: 3.0mm square shank
• Diamond coating length: 20~30mm (Double head)

全長: 155mm 柄徑: $\phi 3.0$ mm 方柄 鑽石長: 20~30mm (雙頭)

形狀 · 尺寸 Shape · Size(mm)	#200	#150	#400
1. 3x2	BF-801	BF-801J	BF-801V
2. $\phi 2$	BF-802	BF-802J	BF-802V
3. $\phi 3$	BF-803	BF-803J	BF-803V
4. $\phi 3$	BF-804	BF-804J	BF-804V
5. 3	BF-805	BF-805J	BF-805V
6. 3	BF-806	BF-806J	BF-806V
★ 套裝 10支組 10 pcs.set	BF-800	BF-800J	BF-800V

鑽石異形銼刀

鐵工用鑽石銼刀

IF-50鐵工用鑽石銼刀

粒度 Grit size : #100

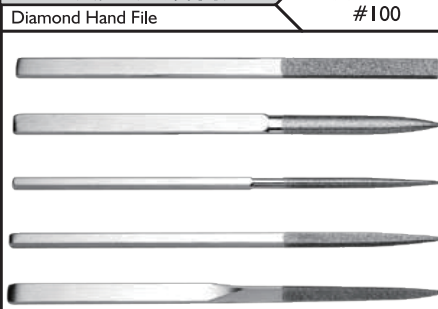

全長 Total length	鑽石長 Dia. length	形狀 Cross-section	編號 Order no.
215	80	3.5	IF-501
215	80	4.4	IF-502
215	80	5	IF-503
215	80	6.3	IF-504
215	80	7.7	IF-505

CF-50鑽石平斜銼刀

粒度 Grit size : #150, #200

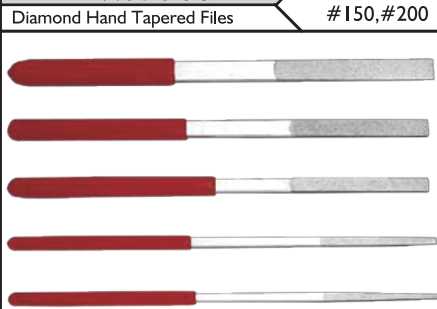

全長 Total length	鑽石長 Dia. length	形狀 Cross-section	編號 Order no.
180	70	2.8~0.9	CF-501
180	60	2.5~0.4	CF-502
180	60	2.5~0.4	CF-503
180	50	2.0~0.4	CF-504
180	50	2.2~0.6	CF-505

CF-500木盒裝5支組 (5p cs. set / wooden case)

金屬結合鑽石銼刀

Sintered Diamond Files

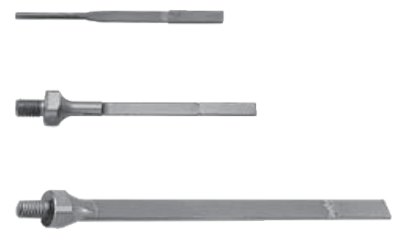

全長 Total length	鑽石長 Dia. length	形狀 Cross-section	粒度 Grit size	編號 Order no.
54	20	1.5	#200	MMF-615F
			#400	MMF-615V
			#600	MMF-615X
72	20	1.5	#200	MDT-02F
			#400	MDT-02V
			#600	MDT-02X
105	20	2	#200	MDT-03F
			#400	MDT-03V
			#600	MDT-03X

電動及氣動超音波研磨機專用
Special design for pneumatic or ultrasonic lapping machine.

Diamond Bent Files

Diamond Hand Files

精密組鑽石銼刀

Diamond Needle Files

PF-10

• Total length: 140mm
• Tool shank: $\phi 3.0$ mm
• Diamond coating length: 50mm

全長: 140mm, 柄徑: $\phi 3.0$ mm, 鑽石長: 50mm

形狀 · 尺寸 Shape · Size(mm)	#120	#200	#400
1. 5.5x1.5	PF-101	PF-101F	PF-101V
2. 5x2	PF-102	PF-102F	PF-102V
3. $\phi 3$	PF-103	PF-103F	PF-103V
4. 2.5	PF-104	PF-104F	PF-104V
5. 3.5	PF-105	PF-105F	PF-105V
★ 套裝5支組 5 pcs.set	PF-100	PF-100F	PF-100V

PF-20

• Total length: 200mm
• Tool shank: $\phi 4.0$ mm
• Diamond coating length: 70mm

全長: 200mm 柄徑: $\phi 4.0$ mm 鑽石長: 70mm

形狀 · 尺寸 Shape · Size(mm)	#120	#200	#400
1. 8.5x1.6	PF-201	PF-201F	PF-201V
2. 7x2.5	PF-202	PF-202F	PF-202V
3. $\phi 4$	PF-203	PF-203F	PF-203V
4. 3.5	PF-204	PF-204F	PF-204V
5. 4.5	PF-205	PF-205F	PF-205V
★ 套裝5支組 5 pcs.set	PF-200	PF-200F	PF-200V

PF-10L

• Total length: 140mm
• Tool shank: $\phi 3.0$ mm
• Diamond coating length: 70mm

全長: 140mm, 柄徑: $\phi 3.0$ mm, 鑽石長: 70mm

形狀 · 尺寸 Shape · Size(mm)	#120	#200	#400
1. 5.5x1.5	PF-101L	PF-101LF	PF-101LV
2. 5x2	PF-102L	PF-102LF	PF-102LV
3. $\phi 3$	PF-103L	PF-103LF	PF-103LV
4. 2.5	PF-104L	PF-104LF	PF-104LV
5. 3.5	PF-105L	PF-105LF	PF-105LV
6. 5.4x1.5	PF-106L	PF-106LF	PF-106LV
7. 1.7x6	PF-107L	PF-107LF	PF-107LV
8. 6x2	PF-108L	PF-108LF	PF-108LV
9. 5x2	PF-109L	PF-109LF	PF-109LV
10. 6x1.5	PF-110L	PF-110LF	PF-110LV
★ 套裝10支組 10 pcs.set	PF-100L	PF-100LF	PF-100LV

PFL-10

• Total length: 180mm
• Tool shank: $\phi 3.0$ mm cover with PVC vinyl
• Diamond coating length: 25~50mm

全長: 180mm 柄徑: $\phi 3.0$ mm
套膠柄 鑽石長: 25~50mm

形狀 · 尺寸 Shape · Size(mm)	#200	#150	#400
1. 5.5x1.5	PFL-101	PFL-101J	PFL-101V
2. 5x2	PFL-102	PFL-102J	PFL-102V
3. $\phi 3$	PFL-103	PFL-103J	PFL-103V
4. 2.5	PFL-104	PFL-104J	PFL-104V
5. 3.5	PFL-105	PFL-105J	PFL-105V
6. 5.5x1	PFL-106	PFL-106J	PFL-106V
7. 5.5x0.5	PFL-705	PFL-705J	PFL-705V
8. 5.5x0.8	PFL-708	PFL-708J	PFL-708V
9. $\phi 2$	PFL-03	PFL-03J	PFL-03V
10. 5.5x1.5	PFL-01	PFL-01J	PFL-01V
★ 套裝10支組 10 pcs.set	PFL-100	PFL-100J	PFL-100V

PF-30

• Total length: 180mm
• Tool shank: $\phi 3.4$ mm
• Diamond coating length: 60mm

全長: 180mm 柄徑: $\phi 3.4$ mm 鑽石長: 60mm

形狀 · 尺寸 Shape · Size(mm)	#120	#200	#400
1. 7.5x1.5	PF-301	PF-301F	PF-301V
2. 6x2.1	PF-302	PF-302F	PF-302V
3. $\phi 3.5$	PF-303	PF-303F	PF-303V
4. 3	PF-304	PF-304F	PF-304V
5. 4	PF-305	PF-305F	PF-305V
★ 套裝5支組 5 pcs.set	PF-300	PF-300F	PF-300V

PF-70Thin flat type

全長: 140mm, 柄徑: $\phi 3.0$ mm, 鑽石長: 40~50mm

This thin flat type files with 0.5 1.0mm thickness, it is suitable for filing some narrow gap.
• Total length: 140mm, Tool shank: 3.0mm
• Diamond coating length: 40~50mm

PF-70超薄平銼
此系列薄銼適用於窄縫加工

形狀 · 尺寸 Shape · Size(mm)	#150	#200	#400
1. 5.5x0.5	PF-705	PF-705F	PF-705V
2. 5.5x0.8	PF-708	PF-708F	PF-708V
3. 5.5x1.0	PF-710	PF-710F	PF-710V

鑽石 (機械) 平斜銼刀

Diamond Tapered (Hand / Machine) Files

規格 Specifications

單位 Unit:mm

鑽石平斜銼刀

PTF-100



全長 Total length	鑽石長 Dia. length	形狀 Cross-section	粒度 Grit size	編號 Order no.
130	30		#200	PTF-12F
			#400	PTF-12V
			#600	PTF-12X
130	30		#200	PTF-14F
			#400	PTF-14V
			#600	PTF-14X
130	30		#200	PTF-16F
			#400	PTF-16V
			#600	PTF-16X
140	50		#600	PF-103X



10支套裝 10 pcs. set in pvc pouch, contains one each of all above files.

CF-400



全長 Total length	鑽石長 Dia. length	形狀 Cross-section	粒度 Grit size	編號 Order no.
180	40		#150	CF-402J
			#200	CF-402F
			#400	CF-402V
180	50		#150	CF-404J
			#200	CF-404F
			#400	CF-404V
180	50		#150	CF-406J
			#200	CF-406F
			#400	CF-406V
180	50		#150	CF-408J
			#200	CF-408F
			#400	CF-408V



12支套裝 12 pcs. set in pvc pouch, contains one each of all above files.

規格 Specifications

單位 Unit:mm

鑽石機械平斜銼刀

MTP Series

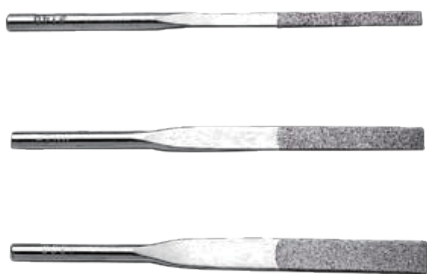

全長 Total length	鑽石長 Dia. length	形狀 Cross-section	粒度 Grit size	編號 Order no.
72	25		#150	MTP-12J
			#200	MTP-12F
			#300	MTP-12H
			#400	MTP-12V
72	25		#150	MTP-14J
			#200	MTP-14F
			#300	MTP-14H
			#400	MTP-14V
72	25		#150	MTP-16J
			#200	MTP-16F
			#300	MTP-16H
			#400	MTP-16V



MTP-120 12支套裝 12 pcs. set in pvc pouch.

MTF Series



全長 Total length	鑽石長 Dia. length	形狀 Cross-section	粒度 Grit size	編號 Order no.
72	15		#200	MTF-13F
			#400	MTF-13V
			#600	MTF-13X
72	15		#200	MTF-16F
			#400	MTF-16V
			#600	MTF-16X
56	15		#200	MTF-23F
			#400	MTF-23V
			#600	MTF-23X
56	15		#200	MTF-26F
			#400	MTF-26V
			#600	MTF-26X



MTP-100 12支套裝 12 pcs. set in pvc pouch.

MPF-10

- Total length: 90mm
- Tool shank: $\phi 3.0$ mm
- Diamond coating length: 45mm



單位 Unit: mm

全長: 90mm 柄徑: $\phi 3.0$ mm 鑽石長: 45mm		編號 Order no.		
形狀 · 尺寸 Shape · Size (mm)		#150	#200	#400
1.	4x1.2	MPF-101	MPF-101F	MPF-101V
2.	5x2	MPF-102	MPF-102F	MPF-102V
3.	$\phi 3$	MFF-103	MPF-103F	MPF-103V
4.	2.5	MPF-104	MPF-104F	MPF-104V
5.	5x2	MPF-109	MPF-109F	MPF-109V
★ 套裝 5支組 5 pcs.set		MPF-100	MPF-100F	MPF-100V

MBF-60

- Total length: 85mm
- Tool shank: $\phi 3.0$ mm
- Diamond coating length: 30mm



單位 Unit: mm

全長: 85mm 柄徑: $\phi 3.0$ mm 鑽石長: 30mm		編號 Order no.		
形狀 · 尺寸 Shape · Size (mm)		#150	#200	#400
1.	5.5x1.2	MBF-601	MBF-601F	MBF-601V
2.	5x2	MBF-602	MBF-602F	MBF-602V
3.	$\phi 3$	MBF-603	MBF-603F	MBF-603V
4.	2.5	MBF-604	MBF-604F	MBF-604V
5.	2.5	MBF-605	MBF-605F	MBF-605V
★ 套裝 5支組 5 pcs.set		MBF-600	MBF-600F	MBF-600V

MBF-90

- Total length: 65mm
- Tool shank: $\phi 3.0$ mm
- Diamond coating length: 20~30mm



單位 Unit: mm

全長: 65mm 柄徑: $\phi 3.0$ mm 鑽石長: 20~30mm		編號 Order no.		
形狀 · 尺寸 Shape · Size (mm)		#150	#200	#400
1.	5.8x1.2	MBF-901	MBF-901F	MBF-901V
2.	3.2x1.4	MBF-902	MBF-902F	MBF-902V
3.	5x2	MBF-903	MBF-903F	MBF-903V
4.	3.2x1.4	MBF-904	MBF-904F	MBF-904V
5.	$\phi 3$	MBF-905	MBF-905F	MBF-905V
6.	$\phi 3$	MBF-906	MBF-906F	MBF-906V
7.	2.5	MBF-907	MBF-907F	MBF-907V
8.	3.2x1.4	MBF-908	MBF-908F	MBF-908V
9.	3.2x1.4	MBF-909	MBF-909F	MBF-909V
10.	3.5x2	MBF-910	MBF-910F	MBF-910V
★ 套裝 10支組 10 pcs.set		MBF-900	MBF-900F	MBF-900V

鑽石切片 & 電鑄鑽石鋸片

Plated Diamond Disc & Electroplated Diamond Cutters

鑽石切片

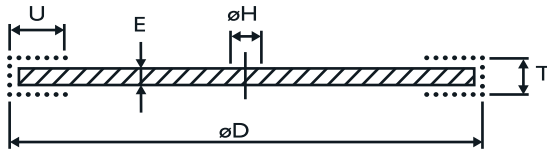

Type A



Type e



規格 Specifications

單位 Unit:mm

編號 Order no.	Type	øD	T	U	E	øH	粒度 Grit	軸柄 Mandrel
BM-190E	E	19	0.4	2	0.2	1.7	#200	A,B,C
BM-190A	A	19	0.4	6	0.2	1.7	#200	A,B,C
BM-220E	E	22	0.4	2	0.2	1.7	#200	A,B,C
BM-220A	A	22	0.4	8	0.2	1.7	#200	A,B,C
BM-250E	E	25	0.4	2	0.2	1.7	#200	A,B,C
BM-250A	A	25	0.5	8	0.2	1.7	#150	A,B,C
BM-300E	E	30	0.4	2	0.2	1.7	#200	A,B,C
BM-300A	A	30	0.5	8	0.2	1.7	#150	A,B,C
BM-221E	E	22	0.4	2	0.2	3.0	#200	D,E,F
BM-221A	A	22	0.4	8	0.2	3.0	#200	D,E,F
BM-251E	E	25	0.4	2	0.2	3.0	#200	D,E,F
BM-251A	A	25	0.5	8	0.2	3.0	#150	D,E,F
BM-301E	E	30	0.4	2	0.2	3.0	#200	D,E,F
BM-301A	A	30	0.5	10	0.2	3.0	#150	D,E,F

軸柄 Mandrel					
編號 Order no.	øD	ød	編號 Order no.	øD	ød
A. AK234	2.34	1.7	D. MK234	2.34	3.0
B. AK300	3.0	1.7	E. MK300	3.0	3.0
C. AK318	3.175	1.7	F. MK318	3.175	3.0

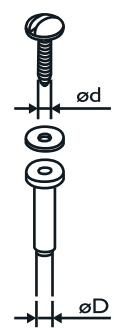

鑽石切片適用於切溝、切斷，研磨下列材質：

玻璃、鋁鋼、陶瓷、石材、硬橡膠、FRP、碳纖維、石磨以及複合材料等

Diamond disc use for grooving, cutting, & grinding the following materials:

glass, tungsten carbide, ceramic, stone, hard rubber, FRP, composite materials and graphite...ets

電鑄鑽石鋸片

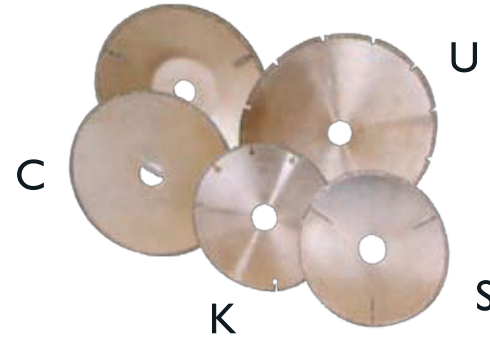
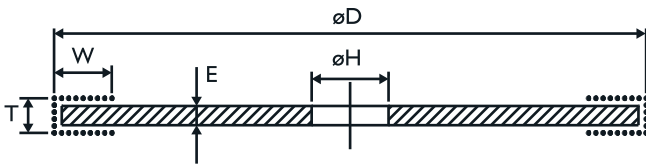

- C: 連續式 Continuous rim type
- U: U溝式 U-slot type
- S: 幅條式 Spoke type
- K: 水滴溝式 Key hole slot type

規格 Specifications

單位 Unit:mm

編號 Order no.	øD	E	T	W	型式 Type	øH	粒度 Grit size
SP-05008	50	0.8	1.8	2~3	C,S,U	訂購時，敬請指明 Depend on your request	#40
SP-06308	63	0.8	1.8	2~3	C,S,U		#40
SP-10008	100	0.8	1.8	2~3	C,S,U		#40
SP-11508	115	0.8	1.8	2~3	C,S,U		#40
SP-11510K	115	1.0	2.0	2~3	K		#40
SP-12508	125	0.8	1.8	2~3	C,S,U		#40
SP-15008	150	0.8	1.8	2~3	C,S,U		#40
SP-15012	150	1.2	2.2	2~3	C,S,U		#40
SP-17512	175	1.2	2.2	2~3	C,S,U		#40
SP-20012	200	1.2	2.2	2~3	C,S,U		#40
SP-25012	250	1.2	2.2	2~3	C,S,U		#40
SP-30012	300	1.2	2.2	2~3	C,S,U		#40

此系列產品主要使用於大理石、磁磚、FRP、碳纖或石墨等之切割
Electroplated Diamond Cutters are used for cutting marble, tile, FRP, carbon or graphics.

標準粒度外，其他粒度請指明訂購

Grit size in the above table is standard for that item, others are available upon request.

訂購砂輪時請指明下列事項：

1. 砂輪之形狀及各部尺寸：如IAI、I4AI
2. 磨料種料：鑽石或氮化硼
3. 粒度：例如：#150
4. 集中度：例如：C-75
5. 結合劑：例如：樹脂結合劑或金屬結合劑
6. 冷卻方式：乾磨或濕磨
7. 數量及交期：
8. 轉速及加工條件：
9. 多數製造商都會在砂輪上標示以下資訊：

When ordering, please specify :

1. Shape & dimensions of wheel : Ex. IAI, I4AI
2. Abrasive : Diamond or CBN
3. Grit size : Ex. #150
4. Concentration : Ex. C-75
5. Bond of wheel : Ex. Resin bond or Metal bond
6. Coolant : Dry or wet grinding
7. Quantity & Delivery date :
8. Spindle speed & grinding conditions :
9. Most of makers marked following information :

SDC 磨料種類 Abrasive	I50 粒度 Grit Size	N 結合度 Grade	75 集中度 Concentration	R 結合劑 Bond	3.0 磨料層厚度 Rim thickness
D : 天然鑽石 Natural diamond	#60	J 軟Soft	25	R : 樹脂結合 Resin bond	1.0mm
SD : 人造鑽石 Synthetic diamond	#80	L	50		1.5mm
	#100	N	75	M : 金屬結合 Metal bond	2.0mm
	#150	P	100	P : 電鑄法 Electroplated	3.0mm
SDC : 人造金屬披覆鑽石 Synthetic metal coating diamond	#200	R 硬Hard	125	V : 陶瓷法 Vitrified	5.0mm
	#270		150		10.0mm
B : 氮化硼 Cubic boron nitride (CBN)	#325				.
	#400				.
BC : 金屬披覆氮化硼 CBN with metal coating	#600				.

使用鑽石與氮化硼時機 Choosing Diamond or CBN ?

* 鑽石

- 碳化鎢，半燒結碳化鎢工具及另件
- 陶瓷工具及另件
- 氧化鐵等之磁性材料
- 耐火材料及其製品
- 石材、寶石及半寶石、貝殼
- 玻璃、石英、瓷器
- 矽、鍺等電子另件
- 碳、石墨及其製品
- 磁磚、瀝青、混凝土、石棉
- 塑膠、加強塑料 (F.R.P.)
- 耐磨耗披覆材料

* Diamond

- Tungsten carbide, presintered carbide metal tools & construction units.
- Oxide ceramic materials.
- Ferrite, ceramic magnetic materials.
- Refractory products.
- Stones, gem & semi-precious stones, shell.
- Glass, porcelain, quartz.
- Graphite, carbon.
- Tiles, asbestos, asphalt, concrete.
- Plastics, F.R.P.
- Wear resistant coatings.

* 氮化硼

- SK,SKS,SKH等切削工具及另件
- SKD,Stellite等耐磨工具鋼材
- SCM,SNCM,SCr,SUJ等構造用鋼
- SUS (不鏽鋼) 等之耐蝕金屬
- SUH鈦合金等之耐熱金屬
- 鑄鐵

* CBN

- High alloy steels.
- High speed tool steels.
- Hot & cold working steels.
- Tempering steels, Spring steel.
- Ball bearing steel.
- Cast iron.

砂輪形狀及尺寸標示

Shape & Dimensions of wheels

<p>1A1</p> <p>__D-__H-__T-__X #__</p>	<p>3A1</p> <p>__D-__H-__J-__T-__U-__X #__</p>	<p>14A1</p> <p>__D-__H-__J-__T-__U-__X #__</p>
<p>6A2</p> <p>__D-__H-__T-__E-__X-__W #__</p>	<p>11A2</p> <p>__D-__H-__K-__T-__E-__X-__W #__</p>	<p>11B2</p> <p>__D-__H-__K-__T-__E-__X-__W #__</p>
<p>12B2</p> <p>__D-__H-__K-__T-__E-__X-__W #__</p>	<p>11C9</p> <p>__D-__H-__K-__T-__E-__X-__U-__W #__</p>	<p>11Y9</p> <p>__D-__H-__K-__T-__E-__X-__U-__W #__</p>
<p>6A9</p> <p>__D-__H-__K-__T-__E-__X-__U #__</p>	<p>11V9</p> <p>__D-__H-__K-__T-__E-__X-__U #__</p>	<p>12V9</p> <p>__D-__H-__K-__T-__E-__X-__U #__</p>
<p>12A2</p> <p>__D-__H-__K-__T-__E-__X-__W #__</p>	<p>4A2</p> <p>__D-__H-__T-__E-__X-__W #__</p>	<p>1FF1</p> <p>__D-__H-__T-__X-__R #__</p>
<p>1L1</p> <p>__D-__H-__T-__X-__R #__</p>	<p>1EE1</p> <p>__D-__H-__T-__X-__V #__</p>	<p>1V1</p> <p>__D-__H-__T-__X-__V #__</p>
<p>9A3</p> <p>__D-__H-__T-__E-__X-__W #__</p>	<p>14U1</p> <p>__D-__H-__J-__T-__X-__U-__W #__</p>	<p>1AIR</p> <p>__D-__H-__T-__X #__</p>

砂輪訂製方法 How to order a wheel?

1. 若是重覆訂製，請告知工作單編號即可 For repeated order, just tell us the manufacturing number.
2. 若需我們為您設計砂輪，則請告知 If you require us to design the wheels for you, please specify :
 - a. 工件名稱，材質，硬度 Name, materials, hardness of work-piece.
 - b. 機器名稱，型式，轉速及馬力 Name, type, horse power, spindle speed of machine.
 - c. 加工條件及加工精度 Grinding conditions.
3. 若自行設計砂輪，則告知如下例： If you have your own design, please order as below :
14A1, 350D-10U-5X-25T-250J-127H, SDC 150N75R5.0, 溼磨 Wet grinding

規格 Specifications

單位 Unit:mm

IIC9碗型砂輪

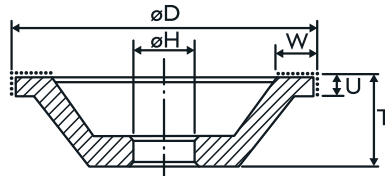

編號 Order no.	D	T	W	H	U	粒度 Grit size
WC-1005A	100	22	10	20	5	#100*
WC-1005B	100	35	10	20	5	#100*
WC-1005C	100	35	10	19.05	5	#100*
WC-1605A	100	35	16	20	5	#200*
WC-2005A	100	35	20	20	5	#200*

適合鎢鋼工具之研磨，成型用。 Ideal for carbide tool's grinding, forming and sharpening.

IAIU

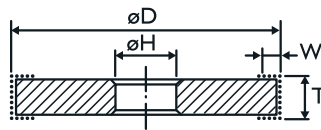

編號 Order no.	D	T	W	H	粒度 Grit size
WS-6105A	150	10	5	31.75	#200*
WS-6105B	150	10	5	12.70	#200*
WS-6105C	150	10	5	15.88	#200*

適合鎢鋼刀具之研磨，成型用。 Ideal for carbide tool's sharpening.

I4YI

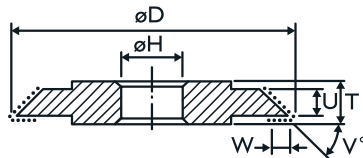

編號 Order no.	D	U	T	W	H	V°	粒度 Grit size
WV-6645A	150	6	10	5	12.70	45	#200*
WV-6645B	150	6	10	5	15.88	45	#200*
WV-6660A	150	6	10	5	12.70	60	#200*
WV-6660B	150	6	10	5	15.88	60	#200*

適合鎢鋼刀具之研磨，成型用。 Ideal for carbide tool's sharpening.

I4AI, I4AIU

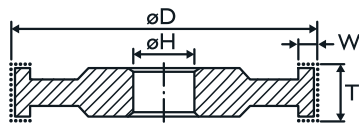

編號 Order no.	D	T	W	H	粒度 Grit size
WS-0625A	150	25	-	25.4	#60*
WS-0625B	150	25	5	25.4	#60*

適合寶石、半寶石、石材研磨，成型用。 Ideal for carbide gem stone and stones grinding.

I4AIU

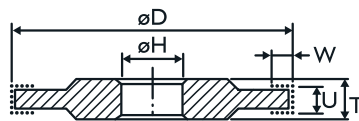

編號 Order no.	D	U	T	E	W	H	粒度 Grit size
WS-7063A	175	6	10	-	3	31.75	#200*
WS-7073A	175	7	10	-	3	31.75	#200*
WS-7083A	175	8	10	-	3	31.75	#200*
WS-7093A	175	9	10	-	3	31.75	#200*
WS-7103A	175	-	10	9.8	3	31.75	#200*
WS-7113A	175	-	11	10	3	31.75	#200*
WS-7123A	175	-	12	10	3	31.75	#200*
WS-7133A	175	-	13	10	3	31.75	#200*
WS-7143A	175	-	14	10	3	31.75	#200*
WS-7153A	175	-	15	10	3	31.75	#200*
WS-7163A	175	-	16	10	3	31.75	#200*

適合鐵粉心之研磨，成型用。 Idea for ferrite core grinding.

9AIU

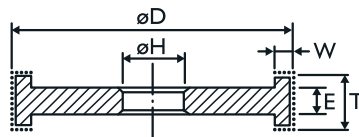

說明：“*” 標準粒度，其餘粒度請指明訂購

規格 Specifications

單位 Unit:mm

I1A2

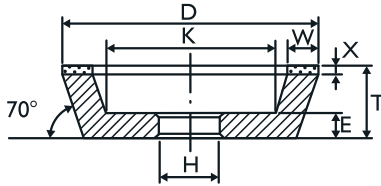

編號 Order no.	D	W	X	T	H	粒度 Grit size
RD-04082A	100	8	2	40	20	SDC-150*
RD-04103A	100	10	3	30	20	SDC-200*
RD-04103C	100	10	3	30	19.05	SDC-200*

適用於工具磨床，鎢鋼刀具研磨及成型
Apply on tool grinding machine, to grind or form the carbide tools.

I1C9

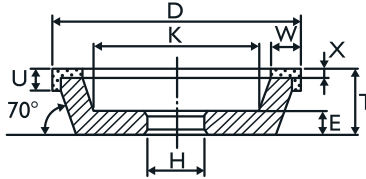

編號 Order no.	D	W	X	U	T	H	粒度 Grit size
RD-04815A	100	8	1	5	40	20	SDC-150*

適用於工具磨床，鎢鋼刀具研磨及成型
Apply on tool grinding machine, to grind or form the carbide tools.

I2Y9C

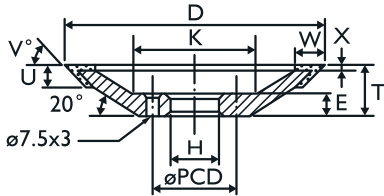

編號 Order no.	D	W	U	X	T	H	V°	形狀	粒度 Grit size
RD-05815A	125	8	-	1	16	25	-	I2A2C	SDC-400*
RD-05815B	125	8	5	1	16	25	60°	I2Y9C	SDC-600*
RD-05815C	125	8	5	1	16	25	45°	I2Y9C	SDC-400*

適用於自動車床刀具研磨機、鎢鋼車刀研磨
For tool grinding machine, to sharpen the carbide turning tools.

IAI

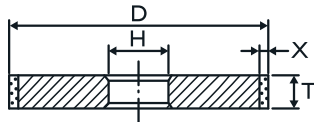

編號 Order no.	D	U	X	T	H	形狀	粒度 Grit size
RD-06033A	150	3	3	10	31.75	I4AI	SDC-150*
RB-06033A	150	3	3	10	31.75	I4AI	BC-150*
RD-06063A	150	6	3	10	31.75	I4AI	SDC-150*
RB-06063A	150	6	3	10	31.75	I4AI	BC-150*
RD-06083A	150	8	3	10	31.75	I4AI	SDC-150*
RD-06103A	150	-	3	10	31.75	IAI	SDC-150*
RB-06103A	150	-	3	10	31.75	IAI	BC-150*
RD-07063A	175	6	3	10	31.75	I4AI	SDC-150*
RD-07103A	175	-	3	10	31.75	IAI	SDC-150*
RB-07103A	175	-	3	10	31.75	IAI	BC-150*
RB-07133A	175	-	3	13	31.75	IAI	BC-150*

適用於平面磨床、研磨鎢鋼、陶瓷(SDC)或硬化鋼材(BC)
Apply on surface grinding machine, to grind carbide(SDC) or hardened steels.

I4AI

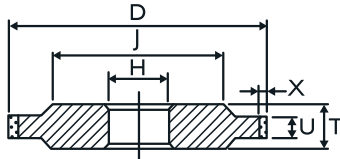

IAIR

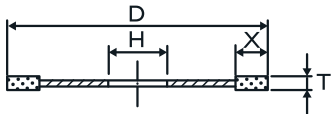

編號 Order no.	D	T	X	H	粒度 Grit size
RD-06017A	150	1.0	7	31.75	SDC-120*
RB-06017A	150	1.0	7	31.75	BC-120*
RD-06017B	150	1.0	7	19.05	SDC-120*

適用於平面磨床(φ31.75孔)或沖頭切斷機(φ19.05孔)用於切斷鎢鋼,陶瓷(SDC)或硬化鋼材(BC)
Apply on surface grinding machine or cutting machine, to cut the carbide, ceramics(SDC) or hardened steels(BC)

說明：“*”標準粒度，其餘粒度請指明訂購 Note：“*”Standard grit size, others depend on your request.

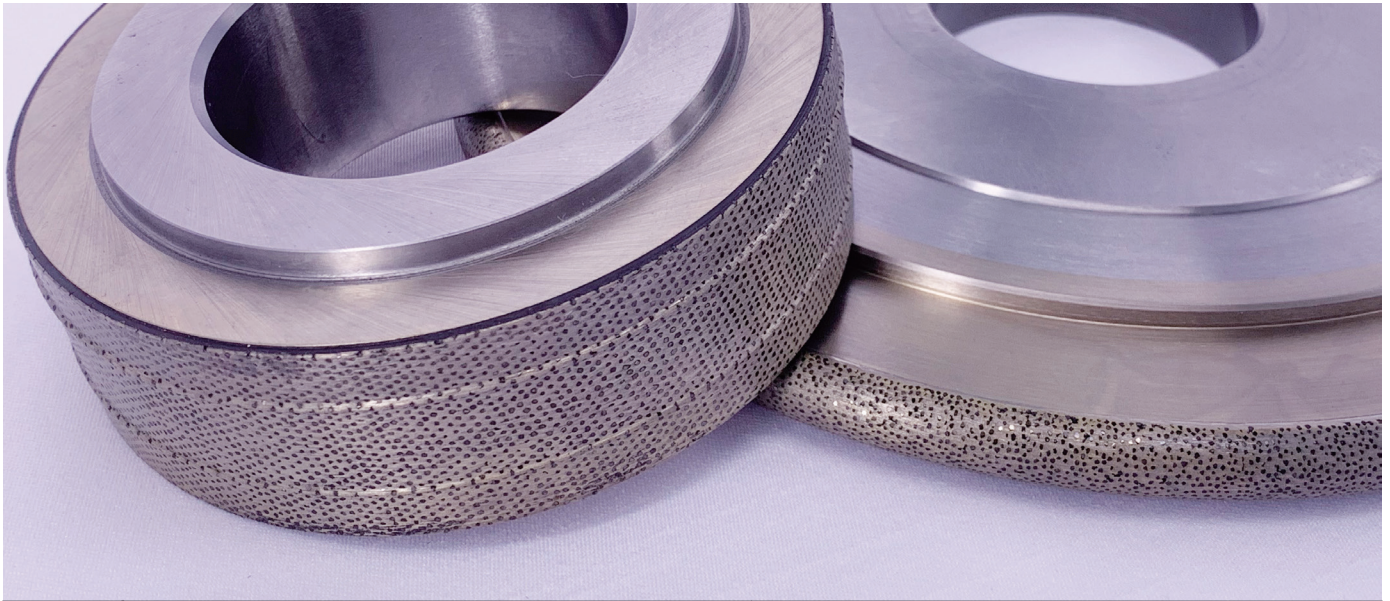

工藝介紹	反轉電鑄	燒結
介紹	使用反轉電鍍將鑽石附著在台金表面，使每一粒磨料在研磨時都能積極參與研磨過程，擁有較長的使用壽命。	將預製好的滾輪安裝在模具中，倒入鑽石與結合劑混和的磨料後進行高溫高壓燒結。待冷卻後修整露出鑽石晶粒。相比於僅晶粒厚度，該工法磨料厚度可達2-3mm。常以修整滾輪或修整碗型的造型製作。
適合	對工件有嚴格公差要求的物件，非常適合精細的型材。	對精度要求不高的簡單型材，可以使型材長期保持原始形狀。適用於修整陶瓷法的CBN砂輪。
鑽石選擇	天然/人造	天然/人造/CVD
鑽石排列	規則/不規則	

介紹：使用鑽石修整滾輪進行砂輪整形時，能夠為製程最佳化提供最佳解決方案，多應用於高精度需求之成形研磨砂輪的修整(材質：氧化鋁、碳化矽、CBN砂輪等)。

適用於：軸承、滾珠螺桿、滑軌、齒輪、刀治具、汽車及航太零件等產業之精密元件。在成形或批量研磨加工時維持砂輪形狀精度的自動化修整作業。

來圖範例：

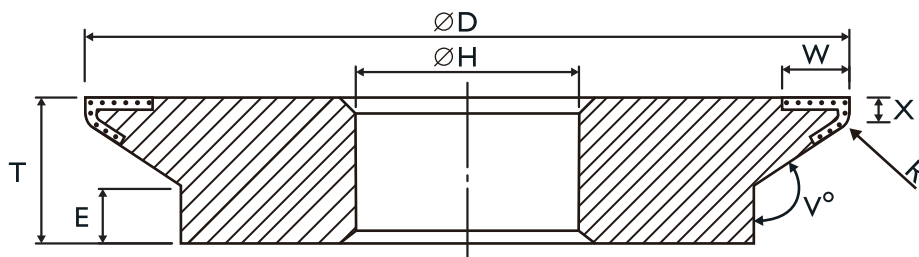

如需客訂歡迎與業務洽詢

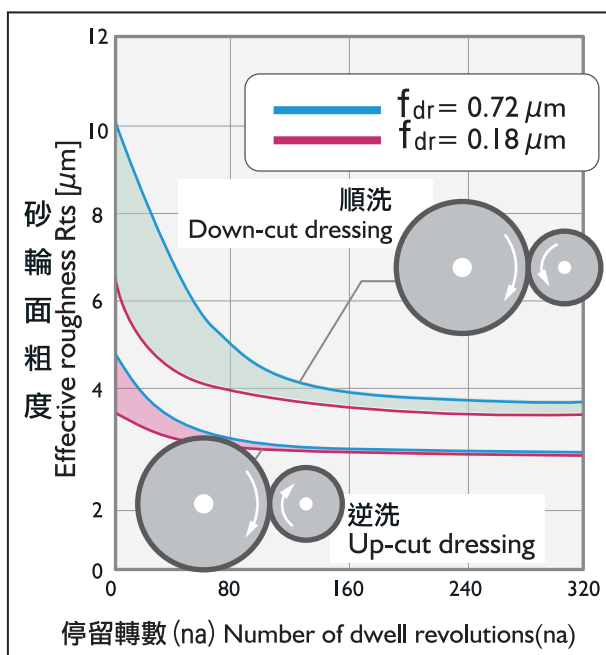
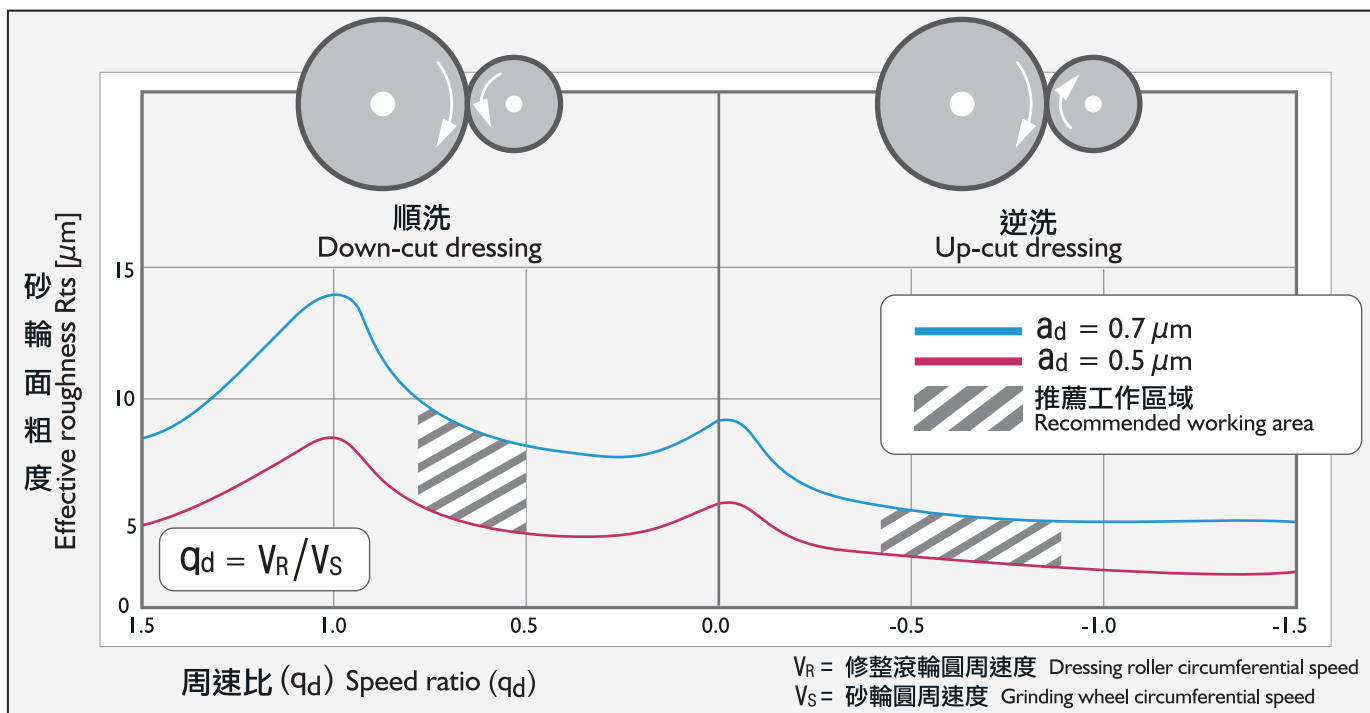

砂輪修整面粗度的4大影響數值

速比 (q_b)：對面粗的影響最大，該值是透過修整滾輪的週轉速與砂輪的週轉數相除獲得的。

※請勿使用1或接近1的速度比，這樣的修整容易使砂輪消耗過快或導致滾輪損壞。

軸向進給速度 (V)：能夠有效影響面粗度，一般而言粗磨修整為100-300mm/min；精磨修整為30-100mm/min。

停留轉數 (n_a)：如左圖，轉速越低，面粗度越大；轉速越高，面粗度越低。當下切修整的停留轉數約為150轉，上切修整的停留轉數約為50轉時，再進一步減少這些值會變得困難。

※儘管可能出現磨削燒傷的情況，也建議保持較低的停留轉數，但當面粗度較高時，應適當提高停留轉數。

進給數率 (Ad)：砂輪每轉一圈滾輪徑向前進的量，如上圖。建議進給量以砂輪每圈0.25-0.5 μm 進給。連續修整時，刀具以砂輪每轉0.2 μm 的速率連續進給。

※修整時，進給量主要取決於修整滾輪的類型、所需要的砂輪輪廓、切削條件、粗磨還細磨，由於應用條件眾多，我們只能建議粗磨以0.1-0.5mm為標準，精磨以0.005-0.05mm為標準。

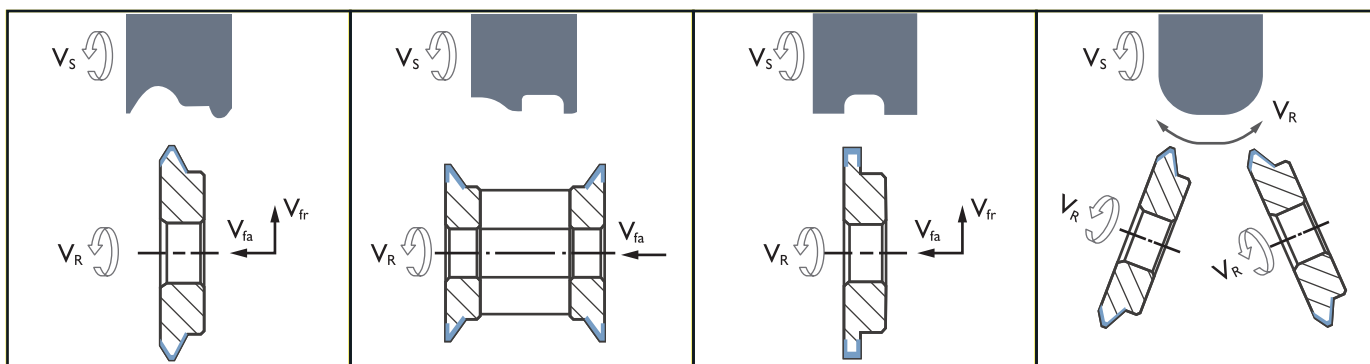

應用方法根據所需的砂輪輪廓，選擇不同類型的滾輪



產品適用範圍

1. 硬質合金, 如: 碳化鈦, 碳化鎢等難加工之材料研拋及倒角(鈍化)可提高刀具壽命和穩定性
2. 藍寶石玻璃及寶石之研磨拋光
3. 光學用藍玻璃毛邊拋修
4. 太陽能矽晶塊研磨拋光
5. 不規則形狀之工件研拋加工, 如玉石雕像, 大型石雕等難拋光之工件

產品使用之優越能

1. 使用於超精密加工工程
2. 具有極佳的研磨效果
3. 具較長之平均使用期限
4. 可運用於嚴苛之酸鹼環境, 亦可耐高溫至270°C, 及具有抗靜電之能力
5. 不同於傳統砂輪, 可加工不規則形體之工件
6. 不同於傳統砂輪, 加工硬脆材料時, 不容易產生崩角或微裂痕
7. 在加工工件時, 對工件本身所殘留的內應力較小

Applications

This product can apply on super hard materials such as Titanium Carbide, Ceramic, Tungsten Carbide, Sapphire and jewelry, Blue Filter Glass, Solar Silicon Wafer etc., and can polish on irregular surface such as jade statue, stone sculpture which are difficult to process.

Advantage

1. Suitable for those precision projects, can have excellent polishing effect, and have longer product life.
2. Can sustain extreme acid and alkali treatment, high temperature up to 270°C and have anti-static ability.
3. Unlike traditional grindstone wheel, diamond brush(wheel) is capable to deal with irregular surface; moreover, and not likely to cause chipping.
4. The residual stress is lesser when applying on the object.

可供應毛刷之粒度表

規格 Specifications

Grit Size
#200
#400
#600
#800
#1000
#2000
#3000
#8000



桌上型旋轉毛刷機 Bench Brushing Machine

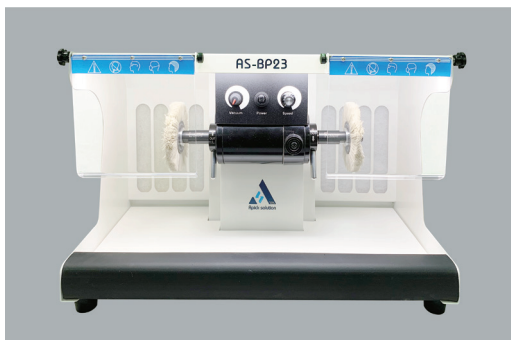

規格 Specification

- 外型尺寸 Appearance size: 500*310*315 mm
 重量 Weight: 15 kg
 電源(選配) Power supply(Optional): 110 or 220 V
 轉速 Rotational Speed: 1240~4500 rpm
 最大拋光輪尺寸 Brushes diameter(max): 127 mm



鑽石毛刷 (輪)

Diamond Nylon Brush / Wheel

DBT系列

型號	番號 No.	柄徑(mm)
DBT-200	#200	ø3.0
DBT-400	#400	
DBT-600	#600	
DBT-800	#800	
DBT-1000	#1000	
DBT-2000	#2000	
DBT-3000	#3000	
DBT-8000	#8000	

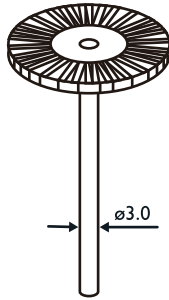

DB系列

型號	番號 No.	柄徑(mm)
DB-200	#200	ø3.0
DB-400	#400	
DB-600	#600	
DB-800	#800	
DB-1000	#1000	
DB-2000	#2000	
DB-3000	#3000	
DB-8000	#8000	

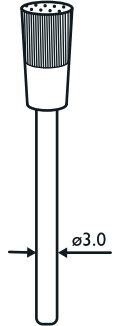

商品特色：

- 需搭配電動研磨機
- 適用硬質類物品：翡翠、水晶、鎢鋼、鈦合金等
- 可克服部分不規則面：鈍化、研磨、拋光
- 尼龍材質，柔軟、耐磨
- 無需另外添加磨料，更環保
- 台灣研發製造

Product features:

- Requires an electric grinder.
- Suitable for hard items: jade, crystal, tungsten steel, titanium alloy, etc.
- Can passivate, grind and polish some irregular surfaces.
- Nylon material, soft and wear-resistant.
- No need to add abrasives, more environmentally friendly.
- Made in Taiwan.

產品注意事項：

- 請勿大力擠壓刷毛以免變形
- 可視情況加水、油降溫以免融掉結塊

Product Notes:

- Do not squeeze the bristles vigorously to avoid deformation.
- Add water and oil as appropriate to cool down to avoid melting and clumping.

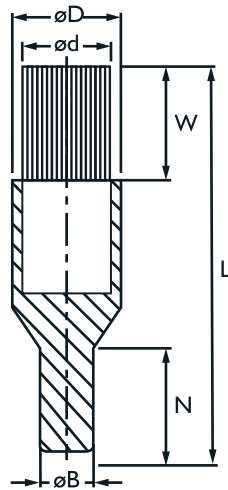

直柄鑽石研磨刷台金規格

規格Specifications			單位Unit: mm				番號 No.
編號 Order no.	øD	ød	W	N	L	øB	番號 選擇 #
DB6-10D	10	8	25	20	70	6	#200
DB6-12D	12	10	25	20	70	6	#400
DB6-16D	16	13	25	20	70	6	#600
DB6-19D	19	16	25	20	70	6	#800
DB6-22D	22	19	25	20	70	6	◎ #1000
DB6-25D	25	23	25	20	70	6	#2000
							#3000
							★ #8000

標準W: 25mm ◎ 有粗細 ★ 非常備品，請與業務洽詢

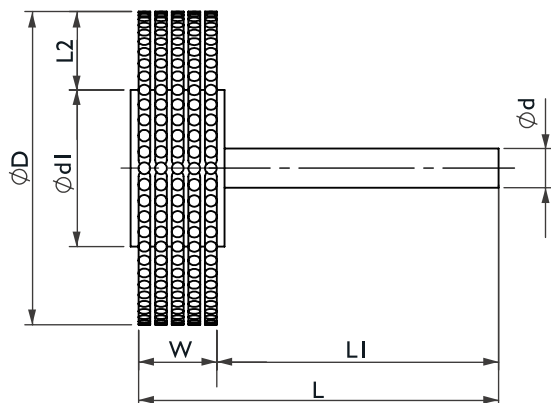

規格Specifications			單位Unit: mm				番號 No.	
編號 Order no.	øD	ød	ødI	W	L1	L2	L	#
DBT25-L6	25.4	6	13	8	31	6.2	46	#200
DBT38-L6	38.1	6	26	8	31	6.1	46	#400
DBT38-L9	38.1	6	20	8	31	9.1	46	#600
DBT38-L12	38.1	6	13	8	31	12.6	46	#800
DBT50-L7	50.8	6	35	8	31	7.9	46	#1000
DBT50-L12	50.8	6	26	8	31	12.4	46	#2000
DBT50-L15	50.8	6	20	8	31	15.4	46	#3000
DBT63-L9	63.5	6	45	8	31	9.3	46	#8000
DBT63-L14	63.5	6	35	8	31	14.3	46	

※產品如有更新換代，可能與以上尺寸有些微誤差，歡迎與業務聯繫洽詢



AR-800(P)



AP-200(Brush Type Only)

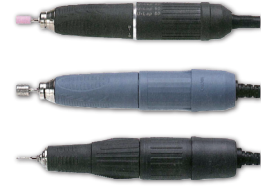

U-Lap 60 , 50 , 35

全新的設計，具有強力的輸出以及精確的控制，擁有多樣化的機種適合每種不同的研磨需求。各種的安全設計避免人員及設備損傷的風險。貼心的功能設計，搭配上精準的轉速控制，讓工作更輕鬆。主機設計以前產地都是台灣製造，兼顧了品質與價格優勢。拋光、研磨、雕刻都能輕鬆應付，初學者也能輕鬆上手。

特長:

*強勁的輸出功率:無刷機型最大250瓦的輸出功率;有刷機型最大150瓦的輸出功率，提供有效且快速加工作業。

*可接受廣域的輸出電壓:所有機型可接受的電源皆為AC90~250V;50/60HZ，不用再為了電源不符合而煩惱，且安全有保障。

*過載保護裝置:當手機處於過載時系統會自動斷電，以保護機器以及手機不至於受損。

*系統自動偵測:先進的高效率微處理可隨時偵測手機狀況，精確地控制各種手機之輸出，保護迴路及扭力補償及穩定轉速，已發揮手機之最佳操作性能。

運用:

各種模具支研磨及拋光。

需要精準控制轉速的加工。

雕刻硬脆材料，話其他需要高轉速的加工。

石頭、玻璃、寶石等之精細研磨或拋光。

工作環境需安靜的場合最為適合。

Brand-new design, with its powerful output and precise controlling function, we provide various models for different grinding needs. Our (brand-new) design mainly focus on all kinds of safety function and avoid any risk of injury while operating the products. With its friendly design and accurate rotational speed control, our products will make your job much easier and efficient. All of our models are made in TAIWAN so the quality and price advantage are both included. It would be much easier to handle polishing, grinding and engraving task, even the beginner can operate it without any difficulties. While using our products.

Features:

*Powerful output : Max.250 watts of output power for our brushless models, Max.150 watts of output power for brush models enables you to achieve any polishing task at the best performance.

*Wide ranges of input voltage are acceptable : Power AC60-260V, 60/60 Hz are all acceptable for our models. No need to worry about the inconsistent power supply.

*Overload protection prevents : Built in overload protection prevents the hand piece from damage during an overloading.

* High-Efficiency microprocessor: Advanced High-Efficiency microprocessor will automatically detects the operation of hand-piece anytime, precisely controlling the output power, circuit protection, torque compensation and maintain the machine in good performance.

Applications:

*For polishing & Grinding of the mold & die.

*Require precise speed control while processing (the work-piece).

*For carving hard & brittle materials or work-piece requiring high-speed procession.

*For fine engraving or polishing of stone, glass and jewelry.

*You can immediately operate the machine by plugging in the power supply. It is highly recommended if the working environment requires serenity.

旋轉式電動工具-電源控制器

Rotary Micromotor Controller





AR-800(P)

AR-800(P)雙功能輸出電源供應器 Dual-function Micromotor Controller		AR-800(P)內含配件 Include(Standard)	
電源 Main supply	AC-90V ~ 250V,50/60 Hz		腳踏開關 Foot Switch
無刷輸出功率 Power of DC brushless	250watt		電源線 Power Cond
無刷轉速 Speed of DC brushless	1,000 ~ 50,000 rpm		
有刷輸出功率 Power of DC brush	150watt(VA)		
有刷輸出電壓 Voltage output of DC brush	5 ~ 32V		
保險絲 Fuse	3.15A		
尺寸 Dimension	170x260x140mm(2.56kg)		

- * 全新設計旗艦型機種，採用先進的高效率微處理器設計，結合有刷及無刷馬達雙輸出。
- * 有刷馬達輸出最大150瓦，無刷馬達輸出最大250瓦，使各種手機有更高的扭力，發揮其最佳的研磨效率。
- * LED轉速顯示，使用無刷手機時，讓您可依據各種不同的工具及外徑，調整最適合的轉速，以達到最有效率且安全的研磨效果。
- * 使用有刷手機時，LED數字顯示輸出電壓，一樣可以換算手機轉速，做最有效率且安全的研磨作業。
- * 先進的高效率微處理器可隨時偵測手機操作狀況，精準地控制各種手機之輸出，保戶迴路及扭力補償及穩定轉速，以發揮手機之最佳操作性能。

- * High Performance micro processor design. Compatible for both brush and brushless motor hand Handpiece.
- * Maximum power for hand piece with brush is 150 watt and 250 watt for brushless motor hand piece, providing high torque and optimal polishing performance.
- * LEO RPM display. The display can be adjusted to suit different tools and sizes to reflect the appropriate RPM information. A safe and efficient polishing is guaranteed.
- * During the use of hand piece with brush, the LED will display voltage, but it can also be converted to display RPM to promote safe and optimal performance operation.
- * Advanced high performance micro processor can passively detect the working condition of the hand piece during usage, precisely adjusting various hand piece output, RPM and torque compensation accordingly and monitor to maintain the performance at maximum. The protection circuit is also monitored to provide best protection.

AR-800(P)可選配手機 AR-800(P) Handpiece Optional		
	U-Lap 60 旋轉手機(無刷型)	Rotary Handpiece(DC Brushless Type) 轉速Speed:50,000rpm 扭力Torque:7.8Ncm 尺寸Size:ø29x161mm 重量Weigh:250g
	U-Lap 50 旋轉手機(有刷型)	Rotary Handpiece(DC Brush Type) 轉速Speed:40,000rpm 扭力Torque:4.5Ncm 尺寸Size:ø29x153mm 重量Weigh:260g
	U-Lap 35 旋轉手機(有刷型)	Rotary Handpiece(DC Brush Type) 轉速Speed:35,000rpm 扭力Torque:2.9Ncm 尺寸Size:ø29x152mm 重量Weigh:230g

* 全部手機皆為選配商品，AR-800(P)內未包含，下單時請注意。 All handpiece are Optional accessory, did not include in AR-800(P)





HANDY-700

HANDY-700電源控制器 Brushless Rotary Micromotor Controller		HANDY-700內含配件 Include(Standard)	
電源 Main supply	AC-110/220V,50/60 Hz		腳踏開關 Foot Switch
輸出功率 Power of DC brushless	230watt		電源線 Power Cond
轉速 Speed Range	1,000 ~ 50,000 rpm		
保險絲 Fuse	3A		
尺寸 Dimension	210x135x188mm(2.4kg)		

- * 轉速指數表(無段變速系統設計輸出從1,000列50000轉)
- * 高扭力、低噪音、低振頻
- * 負載自動保護系統
- * 使用陶瓷培林、耐磨低消耗
- * 具有正逆轉功能
- * 手動/腳踏轉速控制系統
- * 具雙功能雙孔裝置(無碳刷/有刷手機)

- * Digital speed display window.
- * Maximum speed set mode possible.
- * Lowest noise. lowest vibration.
- * Self-diagnosis function.
- * Ceramic ball bearing.
- * Error code display, Auto-cruise function.
- * Vertical & easy-carry system.

HANDY-700可選配手機 HANDY-700 Handpiece Optional		
	U-Lap 60 旋轉手機(無刷型)	Rotary Handpiece(DC Brushless Type) 轉速Speed:50,000rpm 扭力Torque:7.8Ncm 尺寸Size:ø29x161mm 重量Weigh:250g
	U-Lap 50 旋轉手機(有刷型)	Rotary Handpiece(DC Brush Type) 轉速Speed:40,000rpm 扭力Torque:4.5Ncm 尺寸Size:ø29x153mm 重量Weigh:260g
	U-Lap 35 旋轉手機(有刷型)	Rotary Handpiece(DC Brush Type) 轉速Speed:35,000rpm 扭力Torque:2.9Ncm 尺寸Size:ø29x152mm 重量Weigh:230g

* 全部手機皆為選配商品，HANDY-700 內未包含，下單時請注意。 All handpiece are Optional accessory, did not include in HANDY-700.



HANDY-ECO

HANDY-ECO電源控制器 Brushless Rotary Micromotor Controller		HANDY-ECO內含配件 Include(Standard)	
電源 Main supply	100-120V/200-240V,50/60 Hz		變速控制踏板 (FS6ON) Variable speed control pedal (FS6ON)
輸出功率 Power of DC brushless	140watt		電源線 Power Cond
轉速 Speed Range	1,000 ~ 50,000 rpm		
尺寸 Dimension	141x185x97mm(1.6kg)		

作為無刷的非常高的功率控制器，Handy-Eco最引以為豪的是它的空間垂直和水平樣式的應用程序。它有一個圓形支架，可以將手持機放置在機台上。您可以輕鬆地將 Handy-Eco 移動到任何地方，它會是供高品質工作的無刷控制器。可以通過一個控制速度的手控旋鈕，準確並安全作業。

特色

- * 自動安全過載保護系統
- * 數顯速度顯示窗
- * 變速控制踏板 (FS6ON)
- * 可以側放。

Needless to say its very high power as a brushless controller, Handy-Eco is most proud of its space applications for both vertical and horizontal style. It has a round cradle for a motor handpiece with a digital LCD. You can easily move Handy-Eco to anywhere, providing its high quality as a brushless controller. And it can control the speed through a hand dial, targeting at a safety work.

Features

- * Automatic safety overload protection system
- * Digital speed display window
- * Variable speed control pedal (FS6ON)
- * Can be laid on the side.

HANDY-ECO可選配手機 HANDY-ECOHandpiece Optional		
	U-Lap 60 旋轉手機(無刷型)	Rotary Handpiece(DC Brushless Type) 轉速Speed:50,000rpm 扭力Torque:7.8Ncm 尺寸Size:ø29x161mm 重量Weigh:250g

* 全部手機皆為選配商品，HANDY-ECO內未包含，下單時請注意。 All handpiece are Optional accessory, did not include in HANDY-ECO.



AP-200

AP-200有刷多功能輸出電源供應器 Multiple Functional Brush Rotary Power Controller

電源 Main supply	AC-90V ~ 250V,50/60 Hz
無刷輸出功率 Power of DC brush	70watt
有刷輸出電壓 Voltage output of DC brush	5~32V
最大過載保護 Max Overload Current Protection	3A
保險絲 Fuse	2A
尺寸 Dimension	192x156x98mm(800g)



- * AP-200為先進設計的電源控制器，此電源供應器提供了三功能輸出選擇：正常功能、緩啟動功能及扭力自動補償功能。
- * 過負載保護裝置：當電動手機處於過載時系統會自動斷電，以保護機器及手機不至於受損。
- * 可以選購一般開關型或可調速型腳踏開關。
- * AP-200 is a more advanced Power Controller for hand piece with brush. That provide there different output functions: Normal,slow-start, and self torque compensation.
- * Overload Protection: The system will be shut down when an overload occurs to protect the controller and hand piece from damage.
- * Conventional On-Off pedal switch and Adjustable pedal switch are optional.

AP-200內含配件 Include(Standard)



電源線 Power Cond

正常功能輸出(N):

當一般操作時使用，此時系統依一般功能輸出。
Normal Output(N):For use during typical operation.

緩啟動功能(S):

當您切換至此功能時，即使將輸出調到最高轉速，系統仍然控制手機於最低轉速，但接觸工件開始研磨時，系統會自動地將轉速提升到最高轉速。這個功能主要運用於避免高速運轉時不小心去磨到不想磨到或不能磨到的部位，您可以很精確地控制想加工的地方。此外，對於工件表面凹凸不平處這個功能也能減少研磨時之跳動。
Slow Start(S):When switched to this mode, the system will control the RPM to the lowest speed when the hand piece is at idle and when the hand piece detect any object, the RPM will rise to the set speed. The main purpose of this function is to reduce the risk of having accident from happening during high RPM application. We can point at the work area more easily and precisely. This will reduce the chance of accidentally touching under spot. When working on subjects with uneven surfaces under this mode, can keep the hand piece at stable position more easily.

扭力自動補償功能(IR):

當您使用一些直徑較大(如 $\phi 20\text{mm}$ 砂布輪)或不能高速使用的工具(如鬃刷輪)時，由於研磨壓力使轉速下降或較低轉速時扭力較低，當切換至此功能時系統會自動補償扭力穩定轉速。一般研磨工具建議使用正常功能輸出。
Automatic torque Compensation(IR):
When using any large diameter tools or low RPM tools, the PRM will be slowed down due to the friction. When IR mode is turned on, The system will compensate for the loss of speed to stabilize the RPM. When using normal tools, normal function is recommended.

AP-200可選配手機 AR-800(P) Handpiece Optional

	U-Lap 50 旋轉手機(有刷型)	Rotary Handpiece(DC Brush Type) 轉速Speed:40,000rpm 扭力Torque:4.5Ncm 尺寸Size: $\phi 29 \times 153\text{mm}$ 重量Weigh:260g
	U-Lap 35 旋轉手機(有刷型)	Rotary Handpiece(DC Brush Type) 轉速Speed:35,000rpm 扭力Torque:2.9Ncm 尺寸Size: $\phi 29 \times 152\text{mm}$ 重量Weigh:230g

* 全部手機皆為選配商品，AP-200內未包含，下單時請注意。 All handpiece are Optional accessory, did not include in AP-200

電動旋轉手機

Rotary Handpiece

U-Lap 60 無刷旋轉手機/高扭力高轉速型

Rotary Handpiece(Brush Type) / High Torque & Speed Type

可更換夾頭：標準夾頭 $\varnothing 3\text{mm}$ ，亦可選購 $\varnothing 2.34\text{mm}$ 或 $\varnothing 3.175\text{mm}$ 夾頭。

Replaceable collet chuck: $\varnothing 3.0\text{mm}$ is standard, the $\varnothing 2.34\text{mm}$ and $\varnothing 3.175\text{mm}$ collet are optional.

可對應之電源供應器
Optional Power Controller

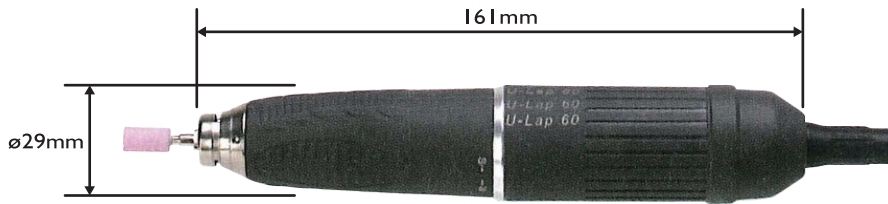

AR-800(P)



AR-600



HANDY-700



HANDY-ECO

轉速Speed: 50,000rpm

扭力Torque: 7.8Ncm

尺寸Size: $\varnothing 29 \times 161\text{mm}$

重量Weigh: 250g

內容物：
include:



U-Lap 50 有刷旋轉手機/高轉速型

Rotary Handpiece(Brush Type) / HighSpeed Type

可更換夾頭：標準夾頭 $\varnothing 3\text{mm}$ ，亦可選購 $\varnothing 2.34\text{mm}$ 或 $\varnothing 3.175\text{mm}$ 夾頭。

Replaceable collet chuck: $\varnothing 3.0\text{mm}$ is standard, the $\varnothing 2.34\text{mm}$ and $\varnothing 3.175\text{mm}$ collet are optional.

可對應之電源供應器
Optional Power Controller

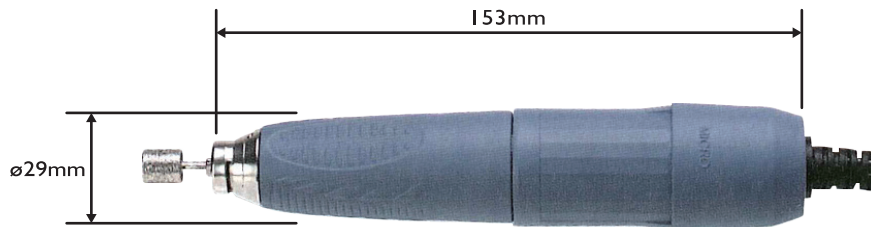

HANDY-700



AR-800(P)



AP-200

轉速Speed: 40,000rpm

扭力Torque: 4.5Ncm

尺寸Size: $\varnothing 29 \times 153\text{mm}$

重量Weigh: 260g

內容物：
include:



U-Lap 35 有刷旋轉手機/經濟型

Rotary Handpiece(Brush Type) / Economic Type

可更換夾頭：標準夾頭 $\varnothing 3\text{mm}$ ，亦可選購 $\varnothing 2.34\text{mm}$ 或 $\varnothing 3.175\text{mm}$ 夾頭。

Replaceable collet chuck: $\varnothing 3.0\text{mm}$ is standard, the $\varnothing 2.34\text{mm}$ and $\varnothing 3.175\text{mm}$ collet are optional.

可對應之電源供應器
Optional Power Controller

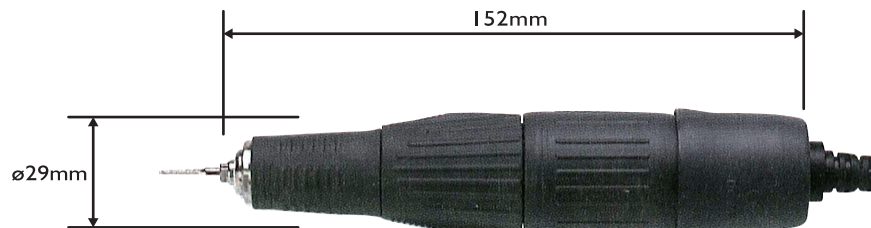

HANDY-700



AR-800(P)



AP-200

轉速Speed: 35,000rpm

扭力Torque: 2.9Ncm

尺寸Size: $\varnothing 29 \times 152\text{mm}$

重量Weigh: 230g

內容物：
include:



超音波振動研磨機，以每秒兩萬多次的超高頻微細振動，可輕鬆地解決各種模具的複雜或細微部位之加工以前難以加工的溝槽、肋骨、角落或複雜及微細等部位，現在使用超音波振動研磨機，將可有效地且省時地完成各種模具之研磨及拋光工作。

Ultrasonic Lapping Machine with micro vibration stroke and extra-high frequency (22,000 times per second), which can easily handle most intricate jobs for various molds and dies. The difficult traditional process of slots, ribs, detail corners, intricate areas becomes so easy with time saving, and efficiently reach a quality result of polishing and finishing process.

特長：* 強勁的輸出功率：最大45瓦的輸出功率，提供有效且快速之加工作業。

* 自動追尾迴路：機器會根據各種不同工具，自動檢測並選擇最佳之輸出振頻以發揮各種工具之最佳性能。

* 電子穩壓變壓器：電子變壓器兼具穩壓效果，即使在電源不穩定之情況下，依然可維持機器良好的操作性能，且可保護機器不致受損。

* 空振檢知迴路設計：當手機未與工件接觸時，機器會自動降低輸出功率，以延長手機壽命，並可防止工具因空振導致發燙或燒毀。

Features: * Powerful output: Max. 45 watts of output power enables you to achieve any polishing task at the best performance.

* Auto feedback system: Machine itself will automatically adjust frequency according to different tools to get the best performance.

* Electronic transformer with regulation: To maintain the machine in good performance and protect it from damage even at an unstable supply of electric voltage.

* Detecting circuit of suspending: When handpiece is not in used, the unit will automatically reduce the output power.

It does not only prolong the life of the handpiece transducer but also keep the tools from heating up.

運用：* 各種磨具之研磨及拋光

* 塑膠製品複雜、精細部位之切斷或去毛邊

* 印刷電路板(PCB)電子迴路修改

* 石頭、玻璃、寶石等之精細雕刻或拋光

* 布、橡膠薄膜之切斷

Applications: * For polish and grinding of the mold & die.

* For cutting and deburning of plastics on intricate area.

* For correction of PCB patterns.

* For fine engraving or polishing of stone, glass and jewelry.

* For cutting of rubber film, cloth, etc.



AR-108



AR-600(E)



AR-600



AR-800

規格 Specifications	單位 Unit: mm			
編號 Order no.	AR-108	AR-600(E)	AR-600	AR-800
電源控制器 Power Controller				
電源 Main supply	AC-90V~250V, 50/60 Hz			
超音波輸出 Ultrasonic output	36 watts	45 watts	45 watts	
振頻 Vibration frequency	18~25 kHz	18~26 kHz	18~26 kHz	
振幅 Stroke amplitude	10~35μm	3~40μm	3~40μm	
振頻調整 frequency adjustment	自動追尋 auto-tarcing			
消耗功率 Power consumption	46 watts	80 watts	100 watts	300 watts
保險絲 Fuse	2A time-lag tybe	2A time-lag tybe		3A time-lag tybe
直流馬達輸出 Output of DC motor	無 None	5~30V		5~32V
有刷輸出功率 Power of DC brush	無 None	Max. 60 watts		Max. 150 watts
無刷輸出功率 Power of DC brushless	無 None	無 None	Max. 100 watts	Max. 250 watts
尺寸 Dimensions (WxDxH)	192x156x96mm	170x240x140mm		170x260x140mm
重量 Weight	0.7 kg	2.0 kg		2.72 kg
手機 Handpiece				
超音波手機 Ultrasonic handpiece	GS-H06	GS-H09		* GS-H26
尺寸 Dimensions (WxDxH)	30x131mm	30x131mm		26x125mm
重量 Weight	185g	210g		170g
旋轉手機 Rotary handpiece				
有刷手機 Brush handpiece	無 None	☆	☆	☆
無刷手機 Brushless handpiece	無 None	無 None	☆	☆

註：* 亦可選用GS-H09手機 Note: GS-H09 could be selected instead of the model.

★ 選購配備 Optional accessory

超音波振動研磨機

Ultrasonic Lapping Machine

AR-800旗艦多功能型 Multi-function Flagship Type

- * 全新設計旗艦型機種，擁有最先進的多功能設計，結合超音波，有刷及無刷直流等三種輸出。
- * 無刷直流輸出最大250瓦，有刷直流輸出150瓦，提供各種手機有更高的扭力，發會其最佳的研磨效果。
- * 先進的高效率微處理器，使用超音波的拋光效果更加穩定，更有效率。
- * 在使用無刷手機時，LED轉速顯示讓您可依據各種不同的工具，調整最適轉速，以達到最有效率且最有安全的研磨效果。
- * 每次啟動機器，系統會自動將轉速歸"零"避免因手機高速啟動而造成危險。
- * 本機之標準配備含有超音波手機(GS-H26)一支。

- * With the most advanced design that provides the multi-function of Ultrasonic, Brush DC(direct-current) and Brushless DC output.
- * All new design with high-efficiency microprocessor that give the machine with perfect performance.
- * The brushless DC with max .250 watts and brush DC with max. 150 watts output power that gives your handpiece with high toque and high speed running.
- * The LED speed display shows you the running speed of brushless hanpiece. You can select the best and safe speed according to various tools and diameter.
- * Once turn on the machine,the system will automatically adjust the speed to " Zero", that keep you away from the damage caused by high speed running of handpiece.
- * This machine includes one ultrasonic handpiece.



AR-600(E)雙功能強力型 Dual-function Powerful Type

- * AR-600(E)為AR208，AR303之升級版。
- * 全新設計，採用高效率微處理器操作性能更穩定且提升拋光效率。
- * 超音波及DC馬達雙輸出，提供您雙重功能之各種研磨及拋光作業。
- * 最大45瓦之超音波輸出，使拋光效率更加提升。
- * 有刷DC馬達輸出電壓為5-30伏特，輸出功率為60瓦。
- * 本機之標準配備含有超音波手機(GS-H09)及有刷旋轉手機(U-Lap35)各一支。
- * AR-600(E)is the upgrade model of AR-208 and AR-303.
- * All new design with high-efficiency microprocessor that gives the machine with more steady and effective performance.
- * This dual-function machine provides you the versatility of both Ultrasonic and mechanical polishing.
- * Max.45 watts Ultrasonic output makes polishing job more effective.
- * Brush DC motor output is 5-30 volt and output power is 60 watts.
- * This machine includes one each of ultrasonic and brushless handpiece.



AR-600三功能實用型 Triple Function Practical Type

- * AR-600採用高效率微處理器設計，使操作性能更穩定且提升拋光效率。
- * 結合超音波，有刷直流及無刷直流三種輸出，滿足更多功能手機使用。
- * 無刷直流輸出功率最大100瓦，有刷輸出為60瓦。
- * 無刷手機的優點為：高轉速、高扭力、壽命長、低噪音、不必更換碳刷且無碳刷產生的粉塵。
- * 本機之標準配備含有超音波手機(GS-H09)及有刷旋轉手機(U-Lap35)各一支。
- * AR-600 with high-efficiency microprocessor design that gives the machine with more steady and effective performance.
- * Combine the Ultrasonic,brush DC and brushless DC output in one package, you can adapt most of the handpiece for your polishing work.
- * Brushless DC output power is 100 watts and brush DC output power is 60 watts
- * The advantage of Brushless handpiece are:high speed,high toeque,longer tool life,and low noise,no need to change carbon brush and no dust cause by carbon brush worn out.
- * This machine includes one each of ultrasonic and brushless handpiece.



AR-108單功能型 Single Function Practical Type

- * 超音波研磨單功能輸出。
- * 具有可信賴的品質及良好的操作性能。
- * 最大40瓦輸出，滿足各種加工需求。
- * 除了模具拋光外，亦可用於電路板(PCB)之電子迴路修改。

- * Ultrasonic lapping function only.
- * The machine provides reliable quality and good performance.
- * Max.40 Watts output that satisfy difference of polishing works.
- * It is not only effective for lapping task,but also good for correction of PCB patterns.



	編號 Order no.	規格 Specifications	適合機種 Application
	GS-H06	超音波手機Ultrasonic handpiece 最大輸出Max.output:40 watts 尺寸Size:ø30x130mm 重量Weigh:185g	AR-108
	GS-H09	超音波手機Ultrasonic handpiece 最大輸出Max.output:45 watts 尺寸Size:ø33x146mm 重量Weigh:254g	AR-800 AR-600 AR-600(E)
	GS-H26	超音波手機Ultrasonic handpiece 最大輸出Max.output:40 watts 尺寸Size:ø27x125mm 重量Weigh:150g	AR-800
 旋轉手機(有刷型)	U-Lap 35	Rotary handpiece(DC Brush Type) 轉速Speed:35,000rpm 扭力Torque:2.9Ncm 尺寸Size:ø29x152mm 重量Weigh:230g	AP-200 AR-600 AR-600(E) AR-800 HANDY-700
 旋轉手機(有刷型)	U-Lap 50	Rotary handpiece(DC Brush Type) 轉速Speed:40,000rpm 扭力Torque:4.5Ncm 尺寸Size:ø29x153mm 重量Weigh:260g	AP-200 AR-600 AR-600(E) AR-800 HANDY-700
 旋轉手機(無刷型)	U-Lap 60	Rotary handpiece(DC Brushless Type) 轉速Speed:50,000rpm 扭力Torque:7.8Ncm 尺寸Size:ø29x161mm 重量Weigh:250g	AR-600 AR-800 AR-800(P) HANDY-700 HANDY-ECO

UG-500 精密型 Precision type



轉速Speed: 60,000rpm
重量Weight: 110g
尺寸Dimensions: $\phi 20 \times 160$ L(mm)

- 高扭力、低噪音、精密型刻磨機
- 適用於精密研磨及修整作業
- 可更換式夾頭：標準夾頭為 $\phi 30$ mm，亦可選購 $\phi 2.34$ 或 $\phi 3.175$ mm為夾頭

- High-torque, quiet-running and well balance.
- Ideal for precision grinding and finishing works.
- Replaceable collet chuck : $\phi 3.0$ mm is standard, the $\phi 2.34$ and $\phi 3.175$ mm collet are optional.

UG-400 經濟型 Economic type



轉速Speed: 60,000rpm
重量Weight: 130g
尺寸Dimensions: $\phi 17 \times 159$ L(mm)

- 經濟型，適用於精密研磨及修整作業
- 夾頭不可更換：標準品為 $\phi 30$ mm夾頭，若須 $\phi 2.34$ 或 $\phi 3.175$ mm夾頭請指明選購
- 低耗風量，高扭力，品質佳

- Reliable quality and competitive price.
- Fixed type collet chuck : $\phi 3.0$ mm is standard, the tool with $\phi 2.34$ and $\phi 3.175$ mm collet are optional.

UG-300 雙夾頭型 Dual-Collet type



轉速Speed: 35,000rpm
重量Weight: 170g
尺寸Dimensions: $\phi 22 \times 180$ L(mm)

- 重負荷、高扭力，泛用型適於清除毛邊倒角、鑄鋼刀銑磨及焊接面磨除等
- 雙夾頭兩用型：標準為 $\phi 30/\phi 60$ mm夾頭，其他 $\phi 3.175/\phi 6.35$ mm為選購

- High torque, heavy-duty, general-purpose applicable on deburring, chamfering, milling and finishing the welded surfaces...etc.
- Dual collet chuck : $\phi 3.0/\phi 6.0$ mm is standard, the collet of $\phi 3.175/\phi 6.35$ mm is optional.

GP-522 平面研磨機 Angle Surface grinder



轉速Free Speed at 90 psi: 22,000rpm
夾頭Collet chuck: M7螺桿 M7 screw shaft
重量Weight: 200g
尺寸Dimensions: $\phi 16.5 \times 136$ L(mm)

- 適用於平面研磨，倒角及焊接面之修整
- 夾頭：M7螺桿，可鎖接碗形輪或砂布片

- 120 degree angle surface grinder.
- Collet chuck: M7 screw shaft for mounting abrasive cup sheets and abrasive paper disc.
- Ideal for surface grinding, chamfering, deburring and finishing the welded surfaces...etc.

GP-260 精密型 Precision type



轉速Speed: 60,000rpm
重量Weight: 180g
尺寸Dimensions: $\phi 17.5 \times 142$ L(mm)

- 精密型，適用於精密研磨及修整作業
- 夾頭不可更換：標準品為 $\phi 3.0$ mm夾頭， $\phi 2.34$ 或 $\phi 3.175$ mm請指明選購

- Ideal for precision grinding and finishing works.
- Fixed type collet chuck: $\phi 3.0$ mm is standard, the tools with $\phi 2.34$ or $\phi 3.175$ mm collet are optional.

GP-380 高速型 High speed type



轉速Speed: 80,000rpm
重量Weight: 160g
尺寸Dimensions: $\phi 20.3 \times 143$ L(mm)

- 高轉速、精密型刻磨機
- 適用於精密研磨及雕刻作業
- 可更換式夾頭：標準品為 $\phi 3.0$ mm夾頭， $\phi 2.34$ 或 $\phi 3.175$ mm為選購

- High speed, quiet-running and well balance.
- Ideal for precision grinding and finishing works.
- Replaceable collet chuck: $\phi 3.0$ mm is standard, the collet of $\phi 2.34$ or $\phi 3.175$ mm collet are optional.

AG-45 平面研磨機 Angle surface grinder



轉速Speed: 23,500rpm
重量Weight: 180g
尺寸Dimensions: $\phi 17 \times 153 \times 50$ H(mm)

- 45度彎頭平面研磨機，適用於平面研磨，倒角及焊接面之修整
- 夾頭：M7螺桿，可鎖接碗形輪或砂布片

- 45 degree angle surface grinder.
- Collet chuck: M7 screw shaft for mounting abrasive cup wheels and abrasive paper disc.
- Ideal for surface grinding, chamfering, deburring and finishing the welded surfaces...etc.

AG-90 平面研磨機 Angle surface grinder



轉速Speed: 23,500rpm
重量Weight: 170g
尺寸Dimensions: $\phi 17 \times 140 \times 39$ H(mm)

- 90度彎頭平面研磨機，適用於平面研磨，倒角及焊接面之修整
- 夾頭：M7螺桿，可鎖接碗形輪或砂布片

- 90 degree angle surface grinder.
- Collet chuck: M7 screw shaft for mounting abrasive cup wheels and abrasive paper disc.
- Ideal for surface grinding, chamfering, deburring and finishing the welded surfaces...etc..

U-Lap® 氣動銼磨機

Pneumatic Reciprocating Lappers

U-Lap® 氣動左右銼磨機

Pneumatic Swing Lappers

UTR-20 微行程渦輪式氣動超音波 Micro Stroke Turbo Air Lappers

行程Stroke:0.15mm
轉速Speed:35,000spm
重量Weight:190g
尺寸Dimensions:ø28x200mm



- 超高速、微動行程(0.15mm)機種，最適於微細部位及邊角部位之研磨。
- 超低振動，加工角落時沒有撞擊感。

- High speed, micro stroke(0.15mm) and low vibration.
- It suits for details and corner area's lapping.

UTR-30 渦輪式氣動超音波 Turbo Air Lappers

行程Stroke:0.3mm
轉速Speed:30,000spm
重量Weight:220g
尺寸Dimensions:ø28x200mm



- 使用氣動渦輪馬達，維修容易
- 低噪音、低振動、壽命長
- UTR-30適合模具細微部分之加工

- Driven by turbine air motor.
- Low noise, low vibration and durable tool life.
- UTR-30 suits for detail area's lapping.

UTR-70 渦輪式氣動超音波 Turbo Air Lappers

行程Stroke:0.7mm
轉速Speed:28,000spm
重量Weight:220g
尺寸Dimensions:ø28x200mm



- 使用氣動渦輪馬達，維修容易
- 低噪音、低振動、壽命長
- UTR-70適用於高效率及較大面積之研磨

- Driven by turbine air motor.
- Low noise, low vibration and durable tool life.
- UTR-70 suits for general purpose polishing and finishing process of mold and die.

UR-120, UR-300 往復式氣動銼磨機 Recipro Air Lappers

編號Order:UR-120
行程Stroke:1.2mm
轉速Speed:12,000spm
重量Weight:370g
尺寸Dimensions:30x208mm



編號Order:UR-300
行程Stroke:3.0mm
轉速Speed:10,000spm
重量Weight:370g
尺寸Dimensions:30x208mm

- 高扭力、低噪音、低振動
- 較長行程適合大面積之研磨，並適合各種鑄件或零件之清除毛邊及倒角

- High-torque, quiet-running and low vibration.
- Long reciprocating stroke suits for lapping big surfaces, and excellent for deburring or chamfering works of die casting parts.

US-70, US-100 左右橫擺氣動銼磨機 Swing Air Lappers

編號Order:US-70
行程Stroke:0.7mm
轉速Speed:15,000spm
重量Weight:305g
尺寸Dimensions:ø28x205mm



編號Order:US-100
行程Stroke:1.0mm
轉速Speed:11,000spm
重量Weight:305g
尺寸Dimensions:ø28x205mm

- 特殊設計使主要磨耗零件十分容易更換
- 氣動左右橫擺行程
- 適合模具淺溝、深肋及公母模接合面等之研磨，防止研磨時工具滑落而傷及模具之銳角

- Side to side stroke.
- Special design enable the easiest method of changing the consuming or worn out parts.
- Ideal for filing, lapping and polishing shallow surfaces, deep ribs and parting lines.

US-200 左右橫擺氣動銼磨機 Swing Air Lappers

編號Order:US-200
行程Stroke:2.0mm
轉速Speed:16,000rpm
重量Weight:520g
尺寸Dimensions:ø34x205mm



- 氣動左右橫擺行程
- 較大行程，適於較大面積之研磨，並適合各種鑄件或零件之清除毛邊及倒角

- Side to side stroke.
- Bigger swing stroke suit for lapping biggersurface and excellent for deburring or works of die casting parts.

附屬工具 Accessory Tools

電著銼刀
FA series
Electroplated diamond file



電著銼刀
MTP, MTF series
Electroplated diamond file



金屬結合銼刀
Sintered diamond file



超級纖維油石
Ceramic fiber stone



鑽石磨棒
Diamond mounted point



帶柄砂輪
Abrasive mounted point



超音波振動研磨機

Ultrasonic Lapping Machine

AR-800可搭配手機一覽表

Attachment Handpiece for AR-800



電動旋轉手機
Rotary Handpiece

U-Lap 60



選配

Optional Accessory

U-Lap 35



選配

Optional Accessory

U-Lap 50



選配

Optional Accessory

超音波手機
Ultrasonic Handpiece

GS-H26



標準配備

Standard Accessory

GS-H09



選配

Optional Accessory

●若要裝置GS-H09手機須轉換接頭 For connecting GS-H09 handpiece to AR-800

AR-600可搭配手機一覽表

Attachment Handpiece for AR-600



電動旋轉手機
Rotary Handpiece

U-Lap 35



選配

Optional Accessory

U-Lap 50



選配

Optional Accessory

U-Lap 60



選配

Optional Accessory

超音波手機
Ultrasonic Handpiece

GS-H09



標準配備

Standard Accessory

●若要裝置GS-H09 手機須轉換接頭 For connecting GS-H09 handpiece to AR-800

AR-600(E)可搭配手機一覽表

Attachment Handpiece for AR-600 (E)



電動旋轉手機
Rotary Handpiece

U-Lap 35



選配

Optional Accessory

U-Lap 50



選配

Optional Accessory

超音波手機
Ultrasonic Handpiece

GS-H09



標準配備

Standard Accessory

AR-108可搭配手機一覽表

Attachment Handpiece for AR-108



超音波手機
Ultrasonic Handpiece

GS-H06



標準配備

Standard Accessory

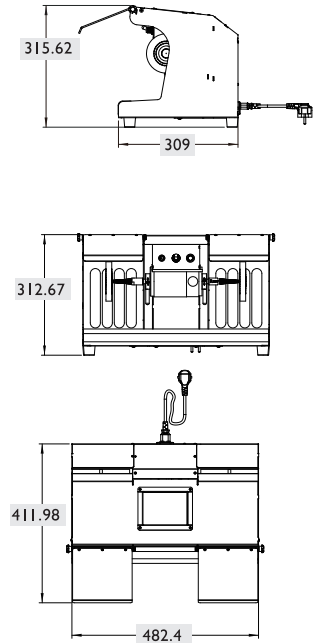
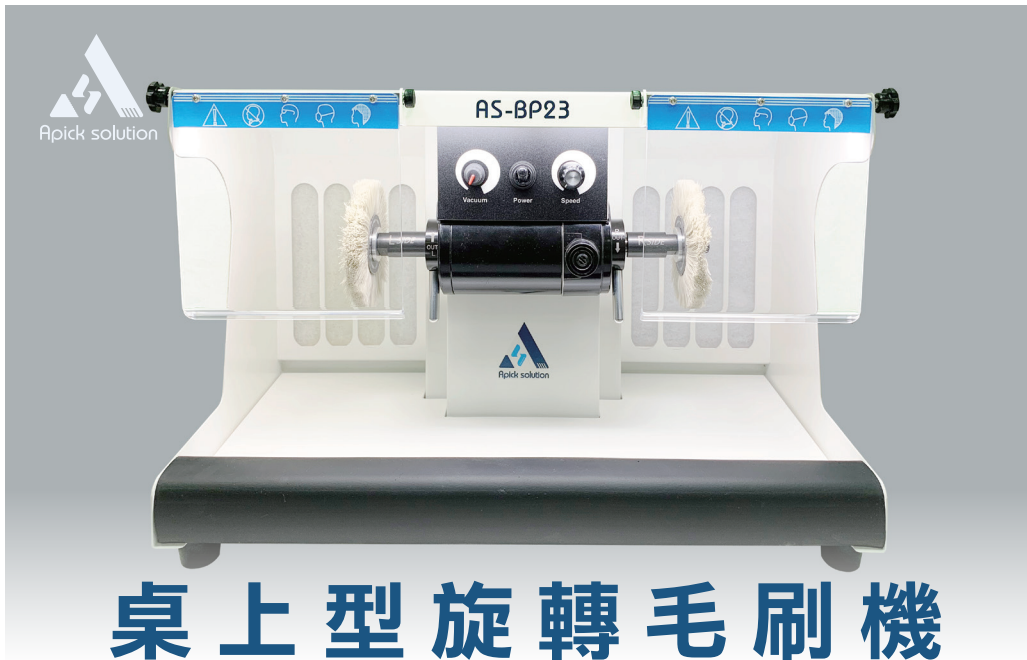

桌上型旋轉毛刷機

BENCH BRUSHING MACHINE

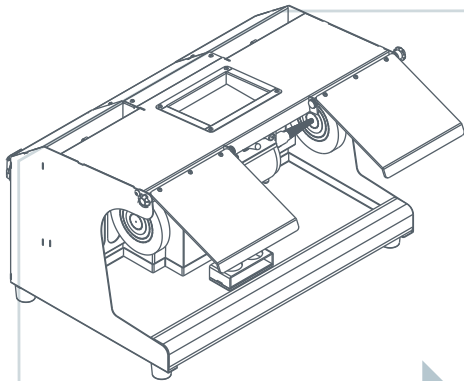

去毛邊

Deburring

倒角

Edge Honing

鈍化

Edge Preparation

拋光

Polishing

特點 Features

AS-BP23

“可依所需調節轉速”

“Adjustable rotational speed as needed”

“可更換多種研磨材質使用”

“Supports interchangeable grinding materials”

“具備粉塵分離的過濾系統”

“Filter system with dust separation”

“設置可調式壓克力保護罩”

“Equipped with adjustable acrylic protective shield”

“兩側設置PU靠墊，長時間較舒適作業”

“PU-cushioned sides for comfortable long-term use”

“設置Led燈照明，讓工作區更為明亮”

“Equipped with LED lighting for brighter workspace”

“輕巧方便且運行平穩又安靜”

“Portable, operates smoothly and quietly”

規格 Specification

型號 Model	AS-BP23
外型尺寸 Appearance size	500*310*315 mm
重量 Weight	15 kg
消耗電力 Power consumption	1.8 A /86.5 W
電源(選配) Power supply(Optional)	110 or 220 V
轉速 Rotational Speed	1240~4500 rpm
風速 Air speed	1080~2190 ft/min
軸數 Number of spindle	2 spindles
照度 Illuminance	3350 lux
操作中分貝值 Noise level	66 dB
最大拋光輪尺寸 Brushes diameter(max)	127 mm
濾網 Filter	8 Merv Rating ,3~10 micron

特點 Features

- 可快速設定加工時間。
- 可簡單快速更換使用各種噴砂材：粗、中、細、亮面。
- 適合工件小型工件：3D列印品(金屬件)、金工首飾、切削刀具、小型模具等小型工件。
- 可做刃口R角鈍化處理，防止刀具崩刃，增加刀具使用壽命，同時也改善並提高被加工表面粗糙度。
- 不僅針對刃口、另外對排屑槽也有拋光平滑效果進而改善刀具排屑能力。
- 柔軟性砂材用於精密零部件之毛邊去除，研磨移除量小，不易塌邊，適合曲面、段差、溝槽等部位噴拋。

應用範例 | Application examples

Comprehensive polishing for various complex-shaped workpieces, ensuring that no areas or narrow gaps are missed.
Suitable for various materials such as ceramics, different alloys, steel, glass, etc.

- Quick setup of processing time.
- Easy & quick replacement of sandblasting materials.
- Suitable for small workpieces: 3D printed parts (metal), metalworking jewelry, cutting tools, small molds, and small workpieces.
- Can be used for rounding and blunting of the cutting edge to prevent tool breakage, increase tool life, and improve surface roughness of the processed material. Also, polishing and smoothing effects on the groove can improve the cutting ability of the tool.
- Soft sandblasting material is suitable for removing burrs from precision components. It has a small grinding removal rate, is not easily collapsed, and is suitable for spraying on curved surfaces, steps, grooves, and other parts.



噴射拋光設備(大) Jet Polishing

Dimensional drawing of the appearance (mm)



噴射拋光設備(小) Jet Polishing

Dimensional drawing of the appearance (mm)



樣品測試前後照片

適用各種複雜形狀工件的全面性拋光，細節狹縫處不漏拋。

適用各種不同的材料的工件，如：陶瓷、各類陶瓷、各類合金、鋼鐵、玻璃等。





附混料機

Attached AS-MIXER

配件 Accessories

| 噴嘴 (Nozzle) : $\varnothing 9$ mm

| 磨料混合器 (Abrasive mixer) : 1 pcs

| 手套 (Gloves) : 1 pair

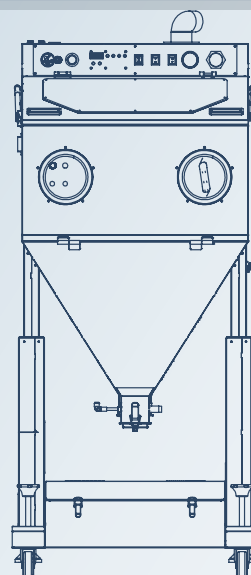
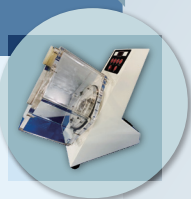

AS-JP23L

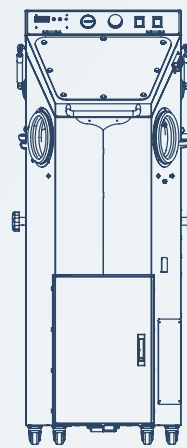

AS-JP23

噴射拋光設備比較 Jet Polishing Equipment Comparison

規格 Specifications		AS-JP23L	AS-JP23
型號	Model	AS-JP23L	AS-JP23
外型尺寸	Appearance size	700 x 911 x 1560 mm	453 x 482 x 1385 mm
門開口尺寸	Entryway size	670 x 320 mm	430 x 350 x 265 mm
腔體尺寸	Internal dimensions	670x450x310(Front D)x455(Back D) mm	Trapezoid 430(Upper W)x265(Down W)x390(L)x230(Front D)x450(Back D) mm
重量	Weight	80 kg	50 kg
電源	Power supply	110V / 220V	
消耗功率	Power consumption	550 W (Max.)	1350 W (Max.)
氣源接入口	Air inlet port	1/2 B	3/8 B
集塵馬達	Dust collector motor	1/4 HP	1 HP
吸砂管尺寸	Sand suction pipe size	16 mm	14 mm
噴砂管材質	Sandblasting nozzle material	矽膠 Silicone	
噴砂調氣功能	Sandblasting air adjustment function	有 Availability	有 Availability
脈衝式集塵器	Pulse-jet dust collector		
內部氣槍	Blasting gun		
氣槍調氣功能	Blasting gun air adjustment function	有 Availability	無 None
底部吹氣功能	Bottom air blow function		
自動升降功能	Automatic lifting function		
可承受工件尺寸	Maximum workpiece size	$\cong 50$ kg	$\cong 30$ kg
可放置工作空間	Maximum working space	550(W) x 350(D) x 250(H) mm	250(W) x 250(D) x 120(H) mm
建議空壓機容量	Recommended air compressor capacity	5HP (3.7kW)	
空壓機濾水器	Air compressor filter	1 set	
半自動治具	Semi-automatic fixture	可選購 Optional	可選購 Optional



可依客戶需求進行調整
各種純度、規格

氧化類	氧化鏷 (La ₂ O ₃)、氧化鈰 (CeO ₂)、氧化鐳釷 ((PrNd) _x O _y)、氧化釷 (Y ₂ O ₃)、氧化鈔 (Sm ₂ O ₃)、氧化鎔 (Eu ₂ O ₃)、氧化鉕 (Tb ₄ O ₇)、氧化鎳 (Dy ₂ O ₃)、氧化釷 (Ho ₂ O ₃)、氧化鉕 (Er ₂ O ₃)、氧化釷 (Gd ₂ O ₃)、氧化鐳 (Pr ₆ O ₁₁)、氧化釷 (Nd ₂ O ₃)、氧化鈳 (Tm ₂ O ₃)、氧化鐳 (Yb ₂ O ₃)、氧化鐳 (Lu ₂ O ₃)、氧化釷 (Sc ₂ O ₃)
氯化類	氯化鏷 (LaCl ₃ ·xH ₂ O)、氯化鈰 (CeCl ₃ ·xH ₂ O)、氯化鐳 (PrCl ₃ ·xH ₂ O)、氯化釷 (NdCl ₃ ·xH ₂ O)、氯化鈔 (YCl ₃ ·xH ₂ O)、氯化鈔 (SmCl ₃ ·6H ₂ O)、氯化鎔 (EuCl ₃ ·6H ₂ O)、氯化鉕 (TbCl ₃ ·xH ₂ O)、氯化鎳 (DyCl ₃ ·6H ₂ O)、氯化釷 (ErCl ₃ ·xH ₂ O)、氯化釷 (GdCl ₃ ·xH ₂ O)、氯化鈳 (TmCl ₃ ·xH ₂ O)、氯化鐳 (YbCl ₃ ·xH ₂ O)、氯化鐳 (LuCl ₃ ·6H ₂ O)
無水氯化類	無水氯化鏷 (LaCl ₃)、無水氯化鈰 (CeCl ₃)、無水氯化鐳 (PrCl ₃)、無水氯化釷 (NdCl ₃)、無水氯化鎔 (EuCl ₃)
氟化類	氟化鏷 (LaF ₃)、氟化鈰 (CeF ₃)、氟化鐳 (PrF ₃)、氟化釷 (NdF ₃)、氟化鈔 (YF ₃)、氟化鈔 (SmF ₃)、氟化鉕 (TbF ₃)、氟化鎳 (DyF ₃)
氫氧化類	氫氧化鏷 (La(OH) ₃)、氫氧化鈰 (Ce(OH) ₄)、氫氧化鐳 (Pr(OH) ₃)、氫氧化鈔 (Sm(OH) ₃ ·xH ₂ O)、氫氧化釷 (Nd(OH) ₃)、氫氧化鎔 (Eu(OH) ₃)
金屬類	金屬鏷 (La)、金屬鈰 (Ce)、金屬鐳 (Pr)、金屬釷 (Nd)、金屬鈔 (Sm)、金屬釷 (Gd)、金屬鉕 (Tb)、金屬鎳 (Dy)、金屬鎳鐵 (Dy-Fe)、金屬釷 (Ho)、金屬釷鐵 (Ho-Fe)、金屬鈳 (Tm)、金屬鐳 (Yb)、金屬釷 (Y)、金屬鐳 (Lu)
硝酸類	硝酸鏷 (La(NO ₃) ₃ ·xH ₂ O)、硝酸鈰 (Ce(NO ₃) ₃ ·6H ₂ O)、硝酸鐳 (Pr(NO ₃) ₃ ·6H ₂ O)、硝酸釷 (Nd(NO ₃) ₃ ·6H ₂ O)、硝酸鈔 (Sm(NO ₃) ₃ ·6H ₂ O)、硝酸鎔 (Eu(NO ₃) ₃ ·xH ₂ O)、硝酸釷 (Gd(NO ₃) ₃ ·xH ₂ O)、硝酸鉕 (Tb(NO ₃) ₃ ·xH ₂ O)、硝酸鎳 (Dy(NO ₃) ₃ ·xH ₂ O)、硝酸釷 (Ho(NO ₃) ₃ ·6H ₂ O)、硝酸鉕 (Er(NO ₃) ₃ ·6H ₂ O)、硝酸鈳 (Tm(NO ₃) ₃ ·6H ₂ O)、硝酸鐳 (Yb(NO ₃) ₃ ·xH ₂ O)、硝酸釷 (Y(NO ₃) ₃ ·xH ₂ O)、硝酸鐳 (Lu(NO ₃) ₃ ·xH ₂ O)、硝酸鈰銨 ((NH ₄) ₂ Ce(NO ₃) ₆)
醋酸類	醋酸鏷 (La(CH ₃ COO) ₃ ·xH ₂ O)、醋酸鈰 (Ce(CH ₃ COO) ₃ ·xH ₂ O)、醋酸鐳 (Pr(CH ₃ COO) ₃ ·xH ₂ O)、醋酸釷 (Nd(CH ₃ COO) ₃ ·xH ₂ O)、醋酸鈔 (Sm(CH ₃ COO) ₃ ·xH ₂ O)、醋酸鎔 (Eu(CH ₃ COO) ₃ ·xH ₂ O)、醋酸釷 (Gd(CH ₃ COO) ₃ ·xH ₂ O)、醋酸鉕 (Tb(CH ₃ COO) ₃ ·xH ₂ O)、醋酸鎳 (Dy(CH ₃ COO) ₃ ·xH ₂ O)、醋酸釷 (Y(CH ₃ COO) ₃ ·xH ₂ O)
草酸類	草酸鏷 (La ₂ (C ₂ O ₄) ₃ ·xH ₂ O)、草酸鈰 (Ce ₂ (C ₂ O ₄) ₃ ·xH ₂ O)、草酸鐳 (Pr ₂ (C ₂ O ₄) ₃ ·xH ₂ O)、草酸釷 (Nd ₂ (C ₂ O ₄) ₃ ·xH ₂ O)、草酸鈔 (Sm ₂ (C ₂ O ₄) ₃ ·xH ₂ O)、草酸鎔 (Eu ₂ (C ₂ O ₄) ₃ ·xH ₂ O)、草酸釷 (Gd ₂ (C ₂ O ₄) ₃ ·xH ₂ O)、草酸鉕 (Tb ₂ (C ₂ O ₄) ₃ ·xH ₂ O)、草酸鎳 (Dy ₂ (C ₂ O ₄) ₃ ·xH ₂ O)、草酸鐳釷 ((PrNd) _x (C ₂ O ₄) _y)
碳酸類	碳酸鏷 (La ₂ (CO ₃) ₃ ·xH ₂ O)、碳酸鈰 (Ce ₂ (CO ₃) ₃ ·xH ₂ O)、碳酸鐳 (Pr ₂ (CO ₃) ₃ ·xH ₂ O)、碳酸釷 (Nd ₂ (CO ₃) ₃ ·xH ₂ O)、碳酸鈔 (Sm ₂ (CO ₃) ₃ ·xH ₂ O)、碳酸鐳釷 ((PrNd) _x (CO ₃) _y)
硫酸類	硫酸高鈰 (Ce(SO ₄) ₂ ·xH ₂ O)
其它	碳化矽 (SiC)、氧化鋁 (Al ₂ O ₃)、氧化鋯 (ZrO ₂)、鈦酸鋇 (BaTiO ₃)、奈米金屬粉、鎳包碳化矽、銅包碳化矽、防偽螢光粉、各類鑽石粉末、cBN立方氮化硼、銅錫粉、燒結粉、多晶/單晶鑽石粉

Various purity and specifications can be adjusted according to your needs.





HONWAY MATERIALS



官方網站

宏歲實業有限公司

HONWAY MATERIALS CO., LTD.

◆ 統編:54218011

☎ +886-7-2231058

☎ +886-7-2230658

🌐 honwaygroup.com

✉ service@honwaygroup.com

📍 80253 高雄市苓雅區光華一路206號8樓之8
8F.-8, No.206, Guanghua 1st Rd., Lingya Dist.,
Kaohsiung City 802, Taiwan (R.O.C.)



LINE@